

BL205 OPC UA Distributed I/O



BL205 User Manual

Version: V1.2

Date: 2023-10-24

Shenzhen Beilai Technology Co.,Ltd

Website: <https://www.bliiot.com>

Preface

Thanks for choosing BLIIoT Distributed I/O. These operating instructions contain all the information you need for operation of BL205.

Copyright

This user manual is owned by Shenzhen Beilai Technology Co., Ltd. No one is authorized to copy, distribute or forward any part of this document without written approval of Shenzhen Beilai Technology. Any violation will be subject to legal liability.

Disclaimer

This document is designed for assisting user to better understand the device. As the described device is under continuous improvement, this manual may be updated or revised from time to time without prior notice. Please follow the instructions in the manual. Any damages caused by wrong operation will be beyond warranty.

Revision History

Update Date	Version	Description	Owner
2021-10-13	V1.0	First Edition	ZLF
2022-07-01	V1.1	Add Profinet, EtherCAT protocol, add platform, logic control functions	HYQ
2023-07-27	V1.1	Change Model name	HYQ
2023-10-24	V1.2	Add BL203, BL206, BL207 description	HYQ
2023-10-24	V1.2	User manual split by model	HYQ

Content

1	Product Introduction	6
1.1	Overview	6
1.2	Typical Application	7
1.3	Features	7
1.4	Model List	7
2	Hardware	9
2.1	EdgeIO Controller	9
2.2	Dimension	9
2.3	Data Contacts/Internal Bus	10
2.4	Power Jumper Contacts	11
2.5	Terminal Point	12
2.6	Factory Reset	12
2.7	Electrical Schematic	13
3	Installation	13
3.1	Installation Sequence	13
3.2	Install Controller	14
3.3	Remove Controller	14
3.4	Insert I/O Modules	15
3.5	Remove I/O Modules	16
4	Device Connection	16
4.1	Wiring	16
4.2	Power Supply	17
4.2.1	System Power	17
4.2.2	On-site Power Supply	18
4.2.3	Grounding	19
5	BL205 OPC UA EdgeIO Controller	19
5.1	BL205 Overview	19

5.2 Technical Parameters	20
5.3 Hardware Interface	21
5.3.1 LED Indicators	21
5.3.2 Ethernet Port	22
5.3.3 IP Address Selection Switch	22
5.4 Modbus Register Mapping	23
5.5 OPC UA Data Point Node Id	24
5.6 Controller Connection	24
5.7 Web Page Configuration	25
5.7.1 Preparation Before Configuration	26
5.7.1.1 Connect Computer and Controller	26
5.7.1.2 Configure Computer IP Address	26
5.7.1.3 Configure Controller IP address	29
5.7.1.4 Factory Default Settings	30
5.7.2 Login Configuration Page	31
5.8 Web Configuration Page Description	32
5.8.1 Status	32
5.8.2 System	34
5.8.2.1 System	34
5.8.2.2 Administration	36
5.8.2.3 Backup/Flash Firmware	38
5.8.2.4 Reboot	39
5.8.3 Settings	39
5.8.4 I/O Modules	40
5.8.4.1 Digital Input Module	41
5.8.4.2 Digital Output Module	42
5.8.4.3 Analog Input Module	43
5.8.4.4 Analog Output Module	44
5.8.5 Serial Port Module	45
5.8.5.1 Serial Port Settings	45

5.8.5.2 Modbus Settings	45
5.8.6 Operation and Control	48
5.8.6.1 Arithmetic Operation	48
5.8.6.2 Logical Operation	49
5.8.6.3 Condition Operation	52
5.8.6.4 Example	52
5.8.7 OPC UA	59
6 BL205 Communication Example	61
6.1 Communication Between UaExpert and BL205	61
6.1.1 OPC UA Web Page Configuration	61
6.1.2 Send and Receive Data Using UaExpert Client	62
7 Warranty	67
8 Technical Support	67

1 Product Introduction

1.1 Overview

BL205 controller is a data acquisition and control system based on a powerful 32-bit microprocessor design with Linux operating system, supports OPC UA protocol for quick access to on-site PLC, SCADA, and ERP systems.

The I/O system supports programmable logic control, edge computing, and customized applications, it is widely applicable to a variety of IIoT and industrial automation solutions.

The BL205 I/O system consists of 3 parts: Controller, I/O modules and terminal module.

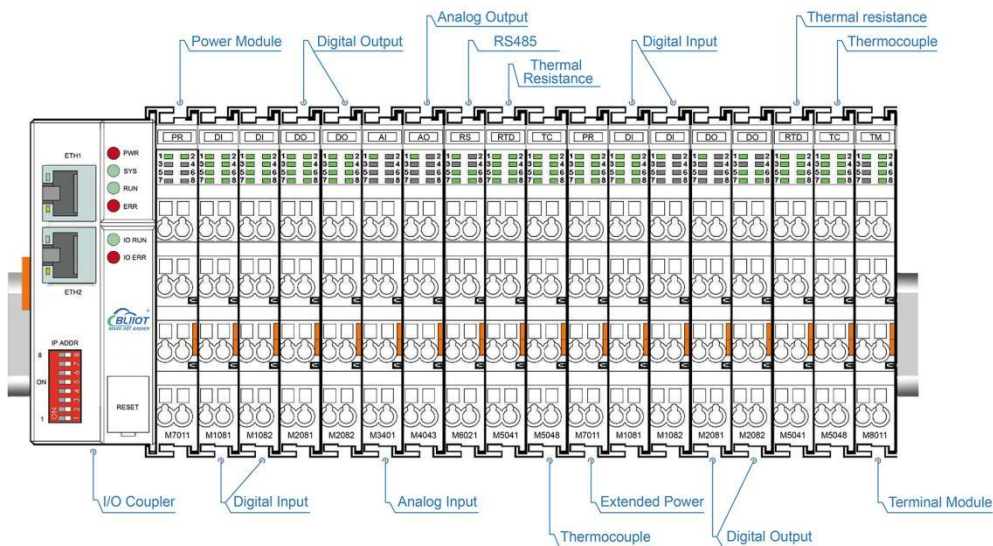

The communication between the node and the field devices (eg PLC) takes place via the Ethernet interface of the fieldbus coupler, and the communication between the fieldbus coupler and the I/O modules takes place via the local bus. The two Ethernet interfaces are internally integrated with a switch function, which can establish a linear topology without the need for additional switches or hubs.

The system needs to use the power module to provide 24VDC system voltage and 24VDC field voltage. Since two independent power supplies are used, the field voltage input interface and system voltage input interface of BL205 controller are electrically isolated from each other.

When assembling fieldbus node modules, each I/O module can be arranged in any combination, and it is not required to be grouped by module type.

A terminal module must be plugged into the end of a fieldbus node to ensure correct data transmission.

1.2 Typical Application

High reliability, easy expansion, easy setting, and convenient network wiring, these capabilities let users efficiently adapt the BL205 I/O system to a variety of complex industrial solutions.

The I/O system is widely applicable to a variety of industrial solutions, such as Internet of Things, smart factories, smart cities, smart medical care, smart homes, smart transportation, data center power environment monitoring, electric power, oil monitoring, automobiles, warehousing and logistics and other industries.

1.3 Features

- Each I/O system can have a maximum of I/O 32 modules.
- Support OPC UA server.
- Support programmable logic control, edge computing.
- The field side, the system side and the bus side are electrically isolated from each other.
- Support 2 X RJ45 interface, integrated switch function, can establish line topology, without the need for additional switches or hubs.
- Convenient wiring connection technology, screw-free installation.

1.4 Model List

Description	Model	Channel	Type
Modbus-TCP I/O Coupler	BL200	/	/
Profinet I/O Coupler	BL201	/	/
EtherCAT I/O Coupler	BL202	/	/
Ethernet/IP I/O Coupler	BL203	/	/
OPC UA EdgeIO Controller	BL205	/	OPC UA
MQTT EdgeIO Controller	BL206	/	/
MQTT+OPC UA+Modbus TCP	BL206Pro	/	/
BACnet/IP I/O Coupler	BL207	/	/

BACnet/IP+MQTT+OPC UA	BL207Pro	/	/
8CH DI	M1081	8	NPN (low level trigger)
8CH DI	M1082	8	PNP (high level trigger)
16CH DI	M1161	16	NPN (low level trigger)
16CH DI	M1162	16	PNP (high level trigger)
4CH DO	M2044	4	Relay
8CH DO	M2081	8	PNP
8CH DO	M2082	8	NPN
16CH DO	M2161	16	PNP
16CH DO	M2162	16	NPN
4CH AI Single-Ended	M3041	4	0-20mA/4-20mA
4CH AI Single-Ended	M3043	4	0-5V/0-10V
4CH AI Differential	M3044	4	0-5V/0-10V
4CH AI Differential	M3046	4	±5V/±10V
4CH AO	M4041	4	0-20mA/4-20mA
4CH AO	M4043	4	0-5V/0-10V
4CH AO	M4046	4	±5V/±10V
2CH RTD	M5021	2	3Wire PT100
2CH RTD	M5022	2	3Wire PT1000
2CH RTD	M5023	2	4Wire PT100
2CH RTD	M5024	2	4Wire PT1000
4CH TC	M5048	4	TC(B/E/J/K/N/R/S/T)
2CH RS485	M6021	2	RS485
2CH RS232	M6022	2	RS232
1CH RS485, 1CH RS232	M6023	2	RS485+RS232
Power module	M7011	/	/
Terminal module	M8011	/	/

2 Hardware

2.1 EdgeIO Controller

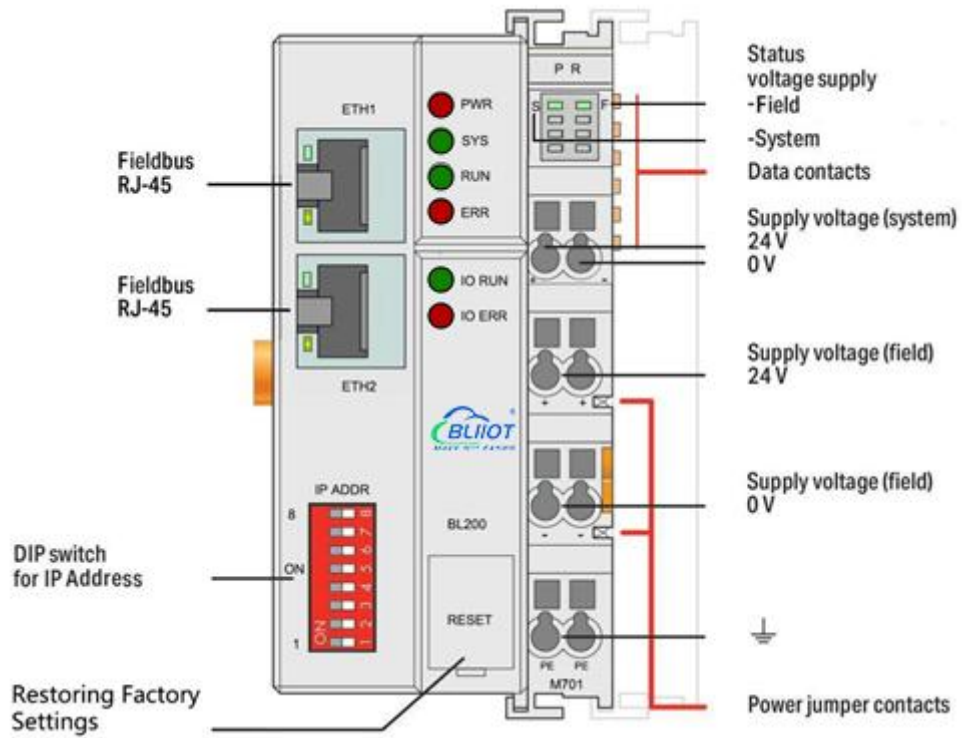

2.2 Dimension

Unit:mm

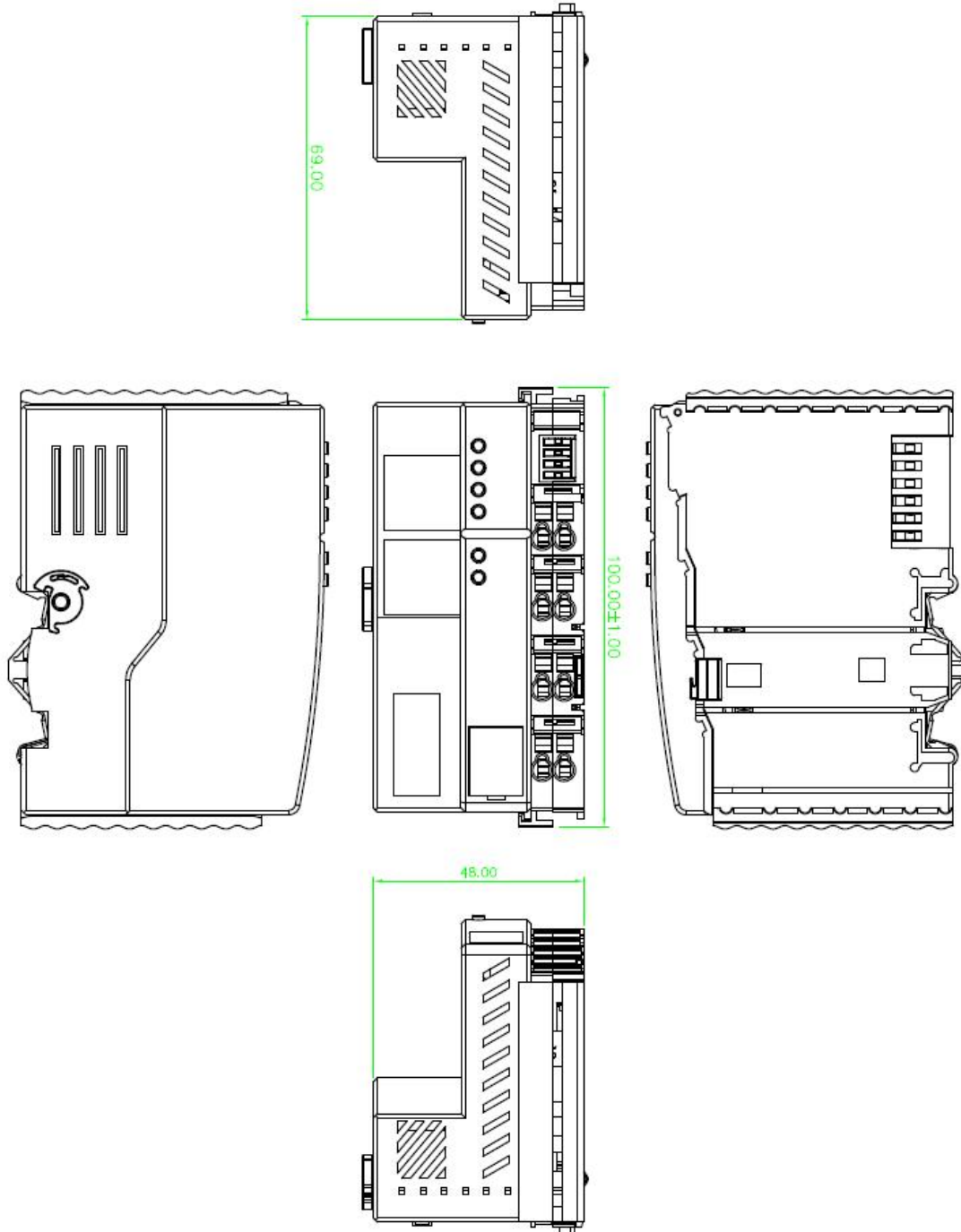

2.3 Data Contacts/Internal Bus

The communication between the I/O controller and the I/O modules, as well as the system power supply of the I/O modules are realized via the internal bus. The internal bus is made up of 6 data contacts, these gold-plated contacts are self-cleaning when connected.

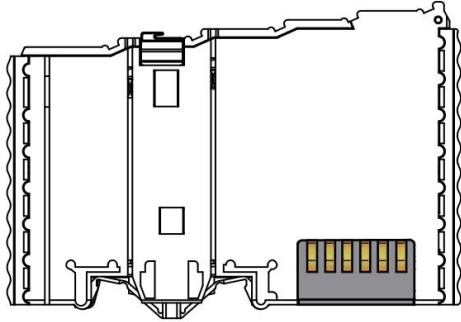

2.4 Power Jumper Contacts

The power module included with the coupler has two self-cleaning power jumper contacts for powering the field side. This power supply has a maximum current of 10A across the contacts, current exceeding the maximum will damage the contacts. When configuring the system, it must be ensured that the above-mentioned maximum current is not exceeded. If it exceeds, a power expansion module needs to be inserted.

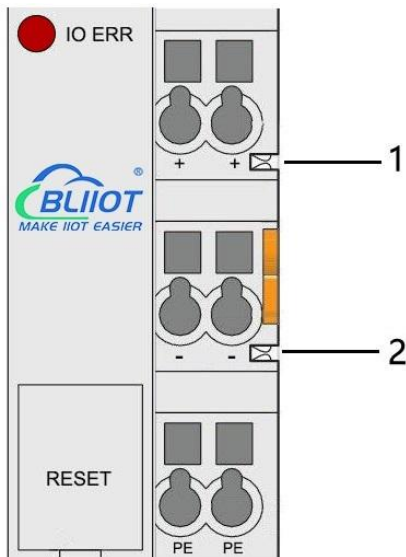

No.	Type	Description
1	Spring contact	Supply 24V to the field side
2	Spring contact	Supply 0V to the field side

2.5 Terminal Point

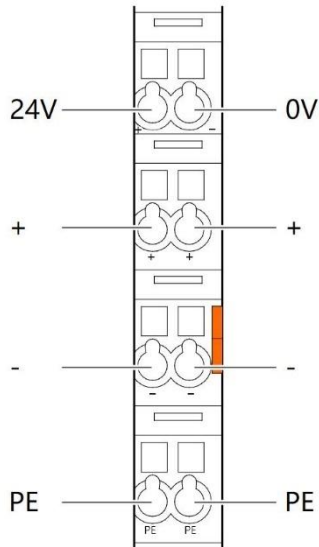

Name	Description
24V	System Power 24VDC
0V	System Power 0VDC
+	Connections Field Supply 24 VDC
+	Connections Field Supply 24 VDC
-	Connections Field Supply 0 VDC
-	Connections Field Supply 0VDC
PE	Grounding
PE	Grounding

2.6 Factory Reset

This reset button is used to restore the device configuration parameters to the factory state.

Operation steps:

1. When the device is running, open the flip cover;
2. Press and hold the button for more than 5 seconds, until all the LED lights go off, indicates reset successful, and then the device will automatically restart.

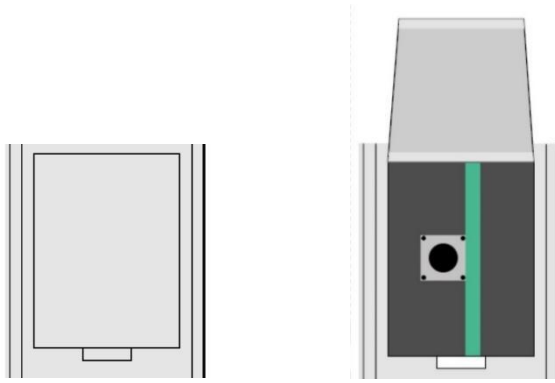

2.7 Electrical Schematic

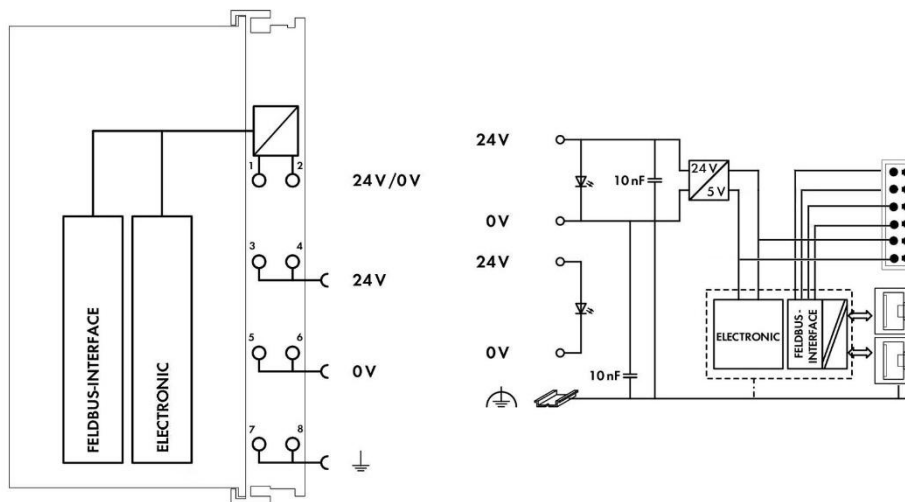

3 Installation

3.1 Installation Sequence

All distributed I/O controllers and I/O modules from Beilai Technology must be mounted on a standard DIN 35 rail.

Starting from the coupler, the I/O modules are assembled from left to right, and the modules are installed next to each other. All I/O modules have grooves and power jumper contacts on the right side, to avoid assembly errors, I/O modules must be inserted from the right and top to avoid damage to the modules.

Utilizes a tongue and groove system to form a secure fit and connection. With the automatic locking function, the individual components are securely fixed on the rail

after installation.

Don't forget to install the terminal module! Always plug a terminal module (eg TERM) into the end of the I/O module to ensure correct data transmission.

3.2 Install Controller

- 1.Snap the controller onto the DIN rail first;
- 2.Use a tool such as a screwdriver to turn the locking cam until the locking cam engages the DIN rail.

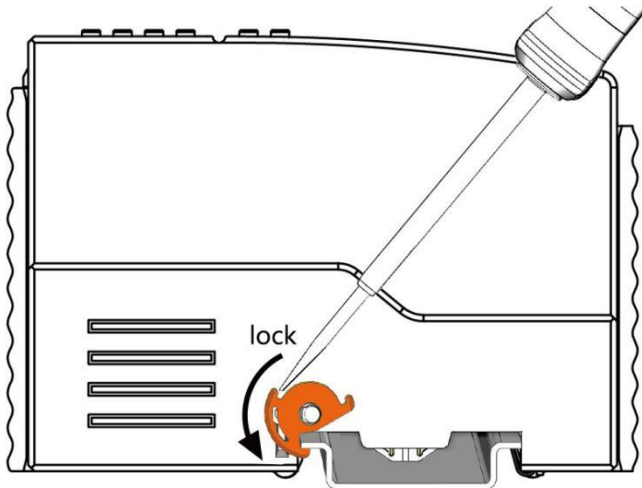

3.3 Remove Controller

- 1.Use a screwdriver to turn the locking disc cam until the locking cam no longer engages the rail.

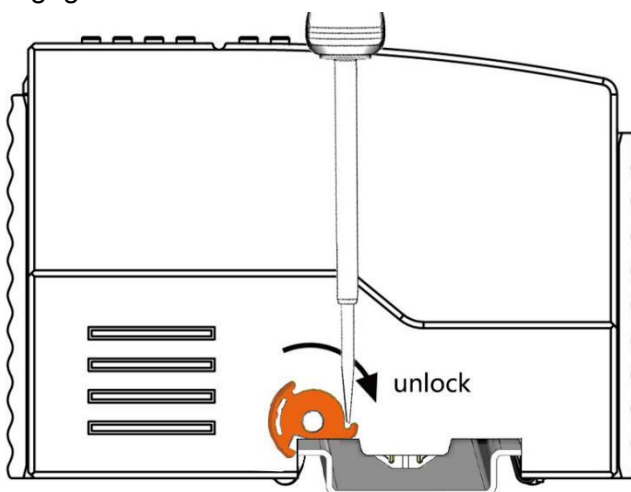

- 2.Pull the release tab to remove the controller from the assembly

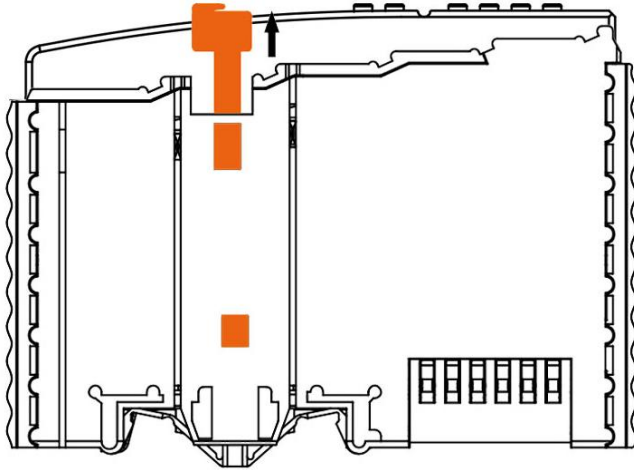

Data or power contacts are electrically disconnected from adjacent I/O modules when the controller is removed.

3.4 Insert I/O Modules

1. When inserting the module, make sure the tabs on the module line up with the grooves of the coupler or other I/O module to which it is attached.



2. Press the I/O module into the assembly position until the I/O module snaps into the rail.

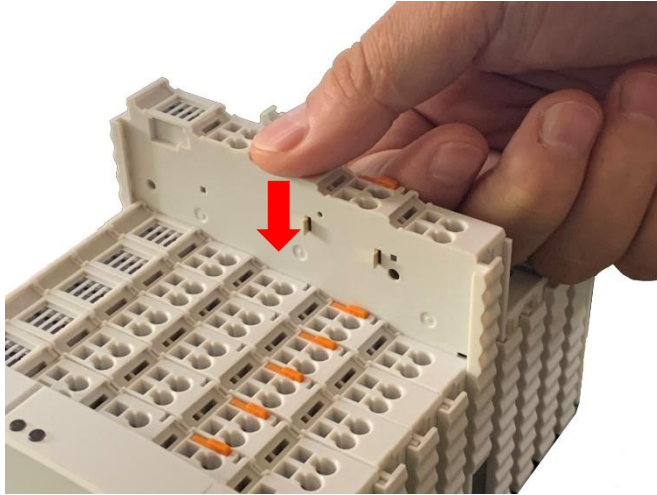

After the I/O module is installed, the electrical connection to the controller (or the previous I/O module) and the following I/O module is established via the data contacts and the power jumper contacts.

3.5 Remove I/O Modules

Pull up on the latch to remove the I/O module from the assembly.

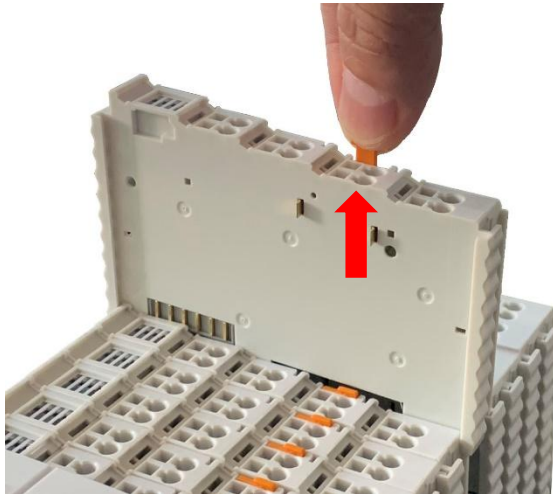

When the I/O module is removed, the electrical connection to the data or power jumper contacts is disconnection.

4 Device Connection

4.1 Wiring

CAGE CLAMP connection is suitable for solid, stranded and fine-stranded conductors. Only one wire can be connected to each CAGE CLAMP. If there is more than one wire,

it must be merged into a point before being connected.

1. Open the CAGE CLAMP by inserting the tool into the opening above the junction.
2. Insert the wire into the corresponding open connection terminal.
3. Once the tool is removed, the CAGE CLAMP closes and the wire is clamped firmly by the spring.

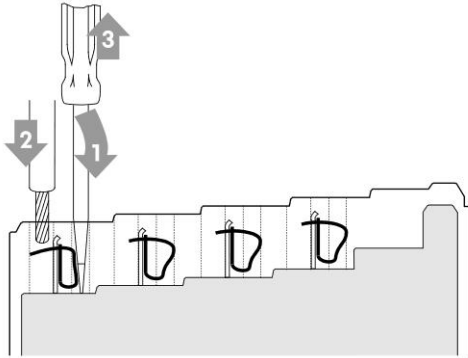

4.2 Power Supply

System and field voltages are supplied by power supply modules. The power supply module of the BL205 controller supplies power for the internal electronics of the controller and the I/O modules. If necessary (there are many I/O modules and the current is relatively high), it can also be provided through an independent power supply module.

The fieldbus interface (Ethernet interface), system and field are galvanically isolated from each other.

4.2.1 System Power

BL205 controller require 24V DC system power, which is connected from the terminal of the power supply module. The 5V bus voltage required inside the system is converted from the 24V system voltage.

The power supply module only has proper fuse protection, please provide proper overcurrent protection externally.

Please pay attention to matching the output power of the power supply module and the load power to avoid excessive load current.

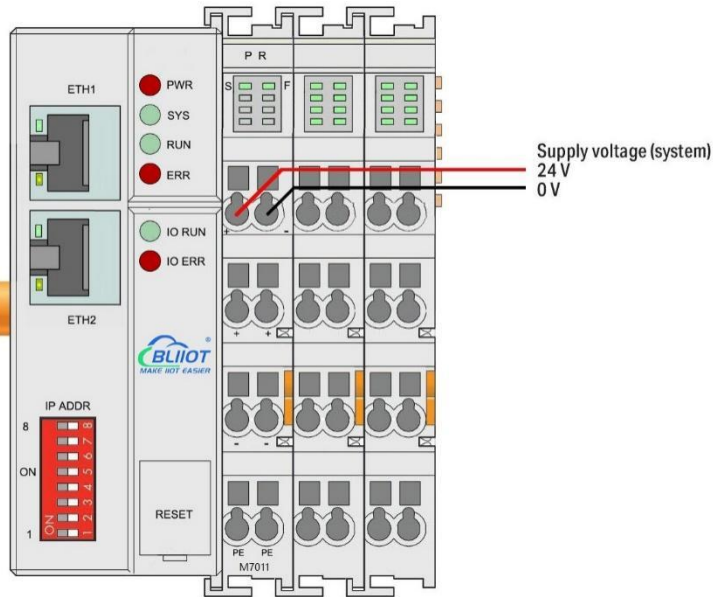

4.2.2 On-site Power Supply

The power supply module supplies 24 VDC on the field side to power the sensors and actuators.

Field power supply only has proper fuse protection. Without overcurrent protection, electronic equipment can be damaged.

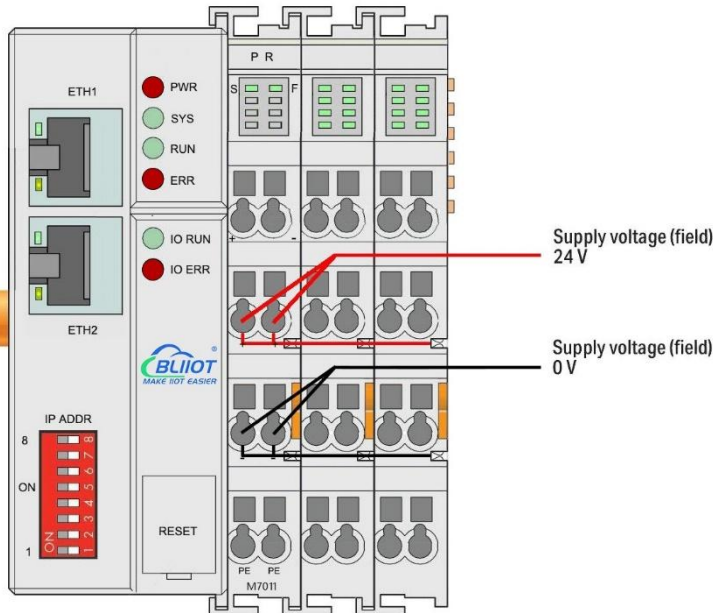

Field-side power is automatically output from the power jumper contact when the I/O module is connected. The continuous load current across the contacts of the power supply must not exceed 10 A.

The problem of excessive load power on the system side or on the field side can be

solved by plugging in additional power supply modules. After plugging in an additional power supply module, a new voltage potential may appear on the field side. In the case where electrical isolation is not required, the field power supply and the system power supply can use the same power supply.

4.2.3 Grounding

When installing the enclosure cabinet, the cabinet must be grounded, and the rail is electrically connected to the cabinet through screws to ensure that the rail is properly grounded. Grounding can increase resistance to electromagnetic interference. Some components in the I/O system have rail contacts that dissipate EMI onto the rail.

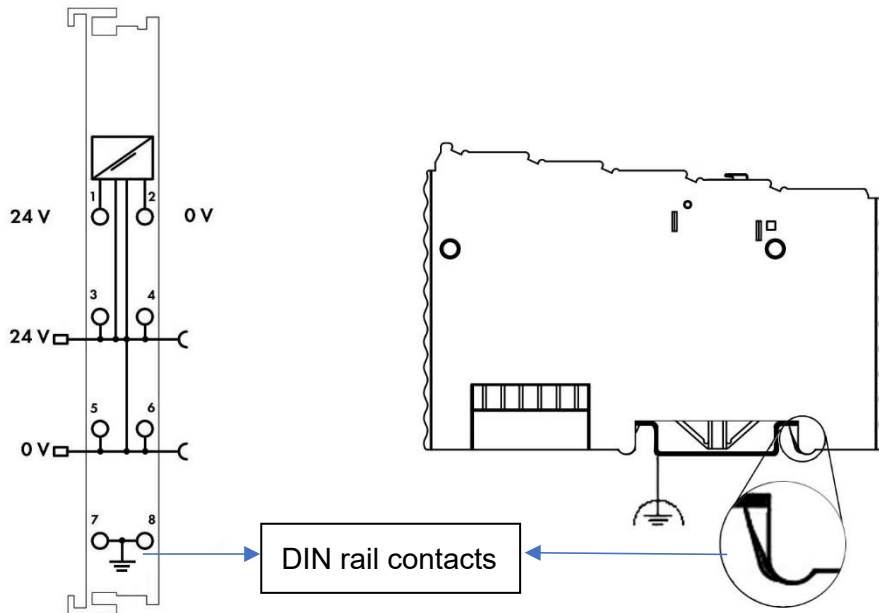

5 BL205 OPC UA EdgeIO Controller

5.1 BL205 Overview

The BL205 controller supports the OPC UA Server function and provides data as a server. Conforms to the IEC 62541 industrial automation unified architecture communication standard, and the data can be transmitted by encryption (X.509 certificate) and identity verification. The security policy supports basic128rsa15, basic256, basic256sha256, aes128sha256rsaoaep, can choose signature or

signature and encryption. Supports the custom information model, and can fill in up to 5 reference models.

5.2 Technical Parameters

Name	Parameters	Description
System power	Input voltage(system)	24 VDC
	Input current(system)	MAX 500 mA@24VDC
	Power Efficiency	84%
	Internal bus voltage	5VDC
	Controller current consumption	MAX 300mA@5VDC
	I/O current consumption	MAX 1700mA@5VDC
	Isolation protection	500 V system/supply
Field power	Input voltage (field)	24 VDC
	Current carrying capacity (power jumper contacts)	MAX 10 ADC
Ethernet	Number	2 X RJ45
	Transmission medium	Twisted Pair STP 100 Ω Cat 5
	MAX cable length	100m
	Baud rate	10/100 Mbit/s
	Isolation protection	ESD contact 8KV, Surge 4KV(10/1000us)
System	Operating system	Linux
	CPU	300MHz
	RAM	64MB
	Flash	128MB
	Number of I/O modules	MAX 32
	Protocols	OPC UA , HTTP, DHCP, DNS
Wiring	Method	CAGE CLAMP
	Wire diameter	0.08 mm ² ... 2.5 mm ² , AWG 28 ... 14
	Strip length	8 mm ... 9 mm / 0.33 in
Environment	Working temperature	0 ... 55 °C
	Storage temperature	-40 ... 70 °C
	Relative humidity	5 ... 95% no condensation
	Working altitude	0 ... 2000 m
	Protection	IP20

Dimension	Width	48mm
	Length	100mm
	Height	69mm
Material	Color	Light gray
	Housing material	Polycarbonate, Nylon 6.6
	Fire load	1.239 MJ
	Weight	180 g
Installation	Method	DIN-35
Certificates	EMC	EN 55022: 2006/A1: 2007 (CE &RE) Class B
		IEC 61000-4-2 (ESD) Level 4
		IEC 61000-4-3 (RS) Level 4
		IEC 61000-4-4 (EFT) Level 4
		IEC 61000-4-5 (Surge)Level 3
		IEC 61000-4-6 (CS)Level 4
		IEC 61000-4-8 (M/S) Level 4

5.3 Hardware Interface

5.3.1 LED Indicators

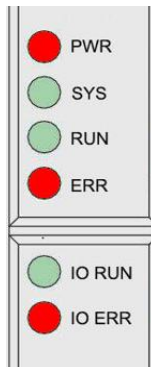

LED	Description	Color	Status	Meaning
PWR	Power indicator	Red	ON	Power connection successful
			OFF	No power
SYS	System indicator	Green	ON	System is abnormal
			OFF	System is running normally
RUN	Running indicator	Green	Flashing	System is running normally
			OFF	System is abnormal

ERR	Error indicator	Red	ON	Northbound protocol connection error
			OFF	No errors
I/O RUN	I/O Running indicator	Green	Flashing	I/O module is working normally
			OFF	Module not inserted
I/O ERR	I/O Error indicator	Red	ON	I/O module communication error
			OFF	No errors



LED	Description	Color	Status	Meaning
S	System 24V power indicator	Green	ON	Power is OK
			OFF	No power
F	Field 24V power indicator	Green	ON	Power is OK
			OFF	No power

5.3.2 Ethernet Port

Connect to the Ethernet-based fieldbus through ETH2.

EHT1 is used to connect other nodes that need to be connected to the Ethernet.

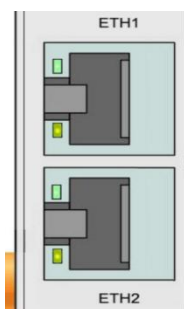

5.3.3 IP Address Selection Switch

The 8-bit DIP switch is used to set the IP address. The encoding of DIP switches is done bit by bit, starting from DIP switch 1 with the least significant bit (2^0) to DIP switch 8 with the most significant bit (2^7), corresponding to decimal values: 0-255.

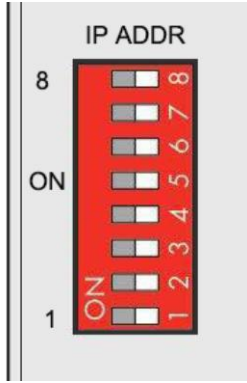

When the value of the DIP switch is 1111 1111 (decimal 255), the IP address is set according to the web page. The web page setting can specify the IP or set the automatic acquisition. When the web page is not set, the IP address is: 192.168.1.10
 When the value of the DIP switch is 0000 0000 – 1111 1110 (decimal 0-254), determine the 3rd byte of the IP address, and the 1st, 2nd and 4th bytes are fixed bytes, namely 192.168.xxx.253

5.4 Modbus Register Mapping

The internal register map of BL205 node consists of 2 parts, one part is the data map of digital input and output and analog input and output module, the address range is 1000...9999; the other part is the serial port module, the address range is 10000...49999

The state of digital and analog I/O modules can be determined or changed through the register map (Address 1000 ... 9999).

I/O Modules

Modbus address		Data type	Access type	Function code	Description
decimal	hex				
1000...1999	0x03 E8...0x07 CF	1 Bit	read/write	0x01/05/0F	Digital output
2000...2999	0x07 D0...0x0B B7	1 Bit	read	0x02	Digital input
3000...3999	0x0B B8...0x0F 9F	32 Bit Float	read	0x04	Analog input
4000...4999	0x0F A0...0X13 87	32 Bit Float	read/write	0x03/06/10	Analog output
5000...8999	0x13 88...0x23 27	32 Bit Unint	read/write	0x03/04/10	DI count value
9000...9999	0x23 28...0x27 0F	1 Bit	read	0x02	Module power-on status

Serial port module

Modbus address		Data type	Access type	Function code	Description
decimal	hex				
10000...19999	0x27 10...0x4E 1F	1 Bit	read/write	0x01/05/0F	Digital output
20000...29999	0x4E 20...0x75 2F	1 Bit	read	0x02	Digital input
30000...39999	0x75 30...0x9C 3F	16 Bit	read	0x04	Analog input
40000...49999	0x9C 40...0XC3 4F	16 Bit	read/write	0x03/06/10	Analog output

5.5 OPC UA Data Point Node Id

The Node Id for OPC UA defaults to NS=1; S=Modbus mapping address of the I/O data point (for example, the first DO module of the first DO module: NS=1; S=1000), custom OPC UA model Node Id can be customized.

5.6 Controller Connection

The BL205 controller comes with 2 x RJ45 Ethernet ports, integrated switch function inside, work in store-and-forward operation mode, each port supports 10/100 Mbit transmission speed and full-duplex and half-duplex transmission mode.

The BL205 controller connect to the router Ethernet network via ETH2 only, while the EHT 1 is for connecting other nodes.

The internal integrated switch supports bypass mode, which can automatically start the bypass mode when the controller system fails, and automatically maintain the link between ETH1 and EHT2.

The wiring of these Ethernet ports conforms to the 100BaseTX specification, which specifies the use of category 5 twisted pair cable as the connecting cable. Cable types S/UTP (Screened unshielded twisted pair) and STP (shielded twisted pair) can be used up to a length of 100m.

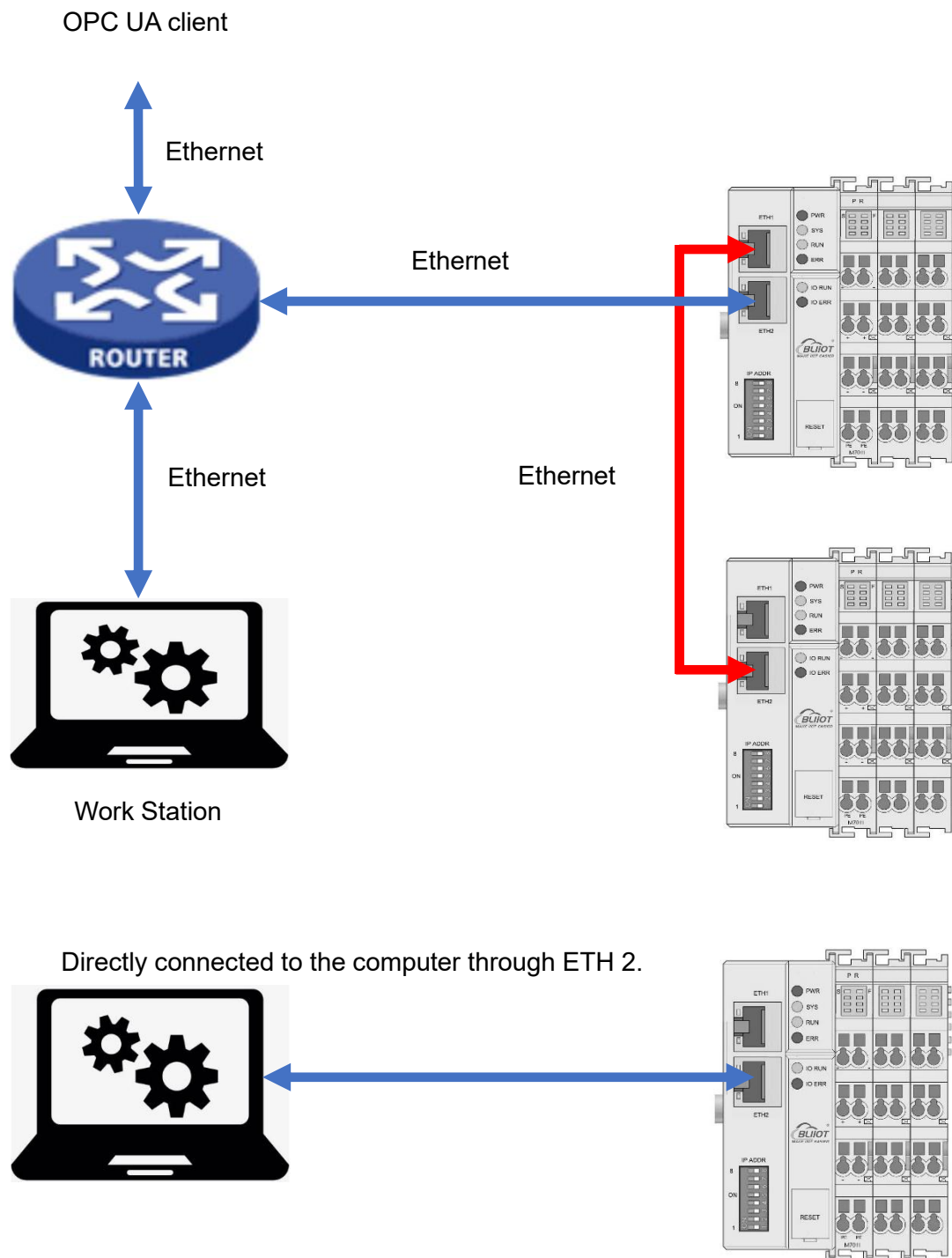

5.7 Web Page Configuration

The BL205 OPC UA Coupler built-in web server is a browser-based configuration

utility. When the node is connected to your network, you can access the web console by entering the server's IP address in a web browser.

5.7.1 Preparation Before Configuration

To successfully access the BL205 controller, it must be properly installed and connected to the computer. In addition, configure them with correct IP addresses to keep them in the same network segment.

5.7.1.1 Connect Computer and Controller

1. Mount the fieldbus node on a DIN35 rail. Follow the installation instructions in the "Installation" chapter.
2. Connect the 24 V power supply to the system power terminals.
3. The computer and the bus node can be connected in two ways, one is that the two are connected to the switch device of the local area network through the Ethernet port; the other is that the two are directly connected point-to-point. For detailed steps, follow the instructions in the "Controller Connection" chapter.
4. Turn on the power supply and start supplying power.

The controller is initialized after power-up, creates process image according to the I/O modules configuration of the fieldbus node.

5.7.1.2 Configure Computer IP Address

There are two ways to configure PC IP address. One is to turn on the automatic IP address option on the PC's local connection to dynamically assign DHCP in the network. The other is to configure a static IP address with the controller node on the same network segment on the local connection of the PC.

Takes Windows 7 system as an example for configuration. Windows systems are all configured similarly.

1. Click Start > Control Panel > Network and Sharing Center, and click local connection in the window that opens.

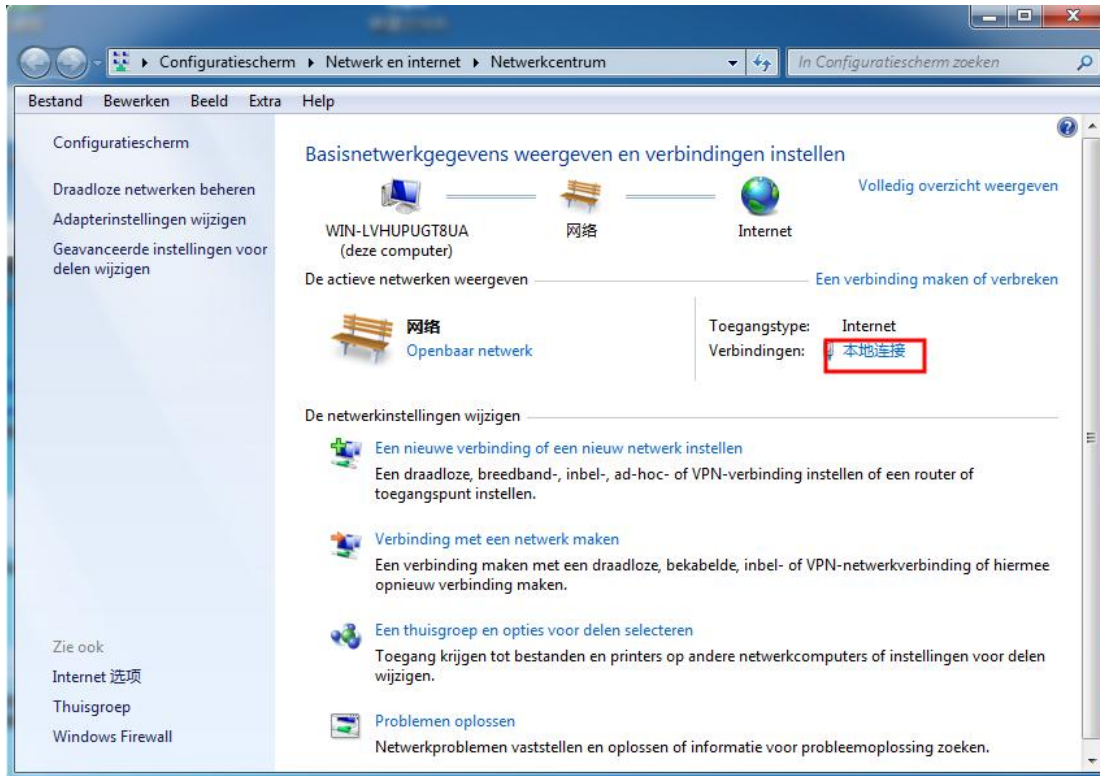

2. In the local connection status window, click Properties.

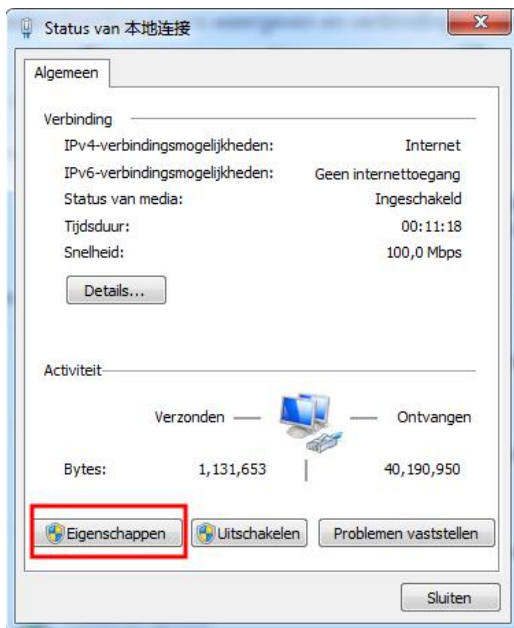

3. Double-click "Internet Protocol Version 4 (TCP/IPv4)" on the local connection properties page.

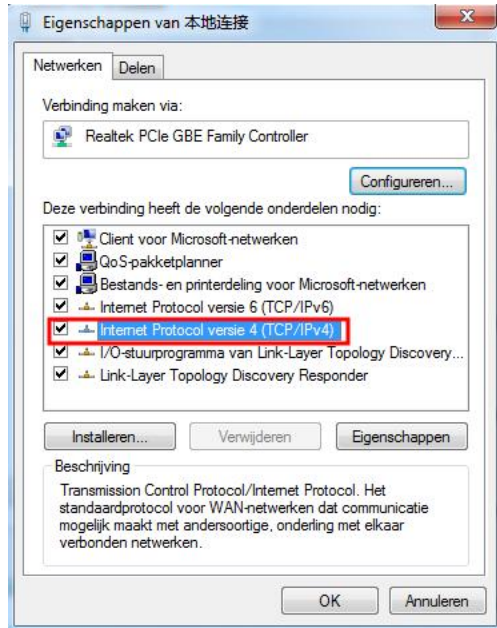

4. There are two ways to configure the IP address of the PC

- Obtain IP address automatically (system default mode)

To obtain an IP address automatically from a DHCP server, select "Obtain an IP address automatically";

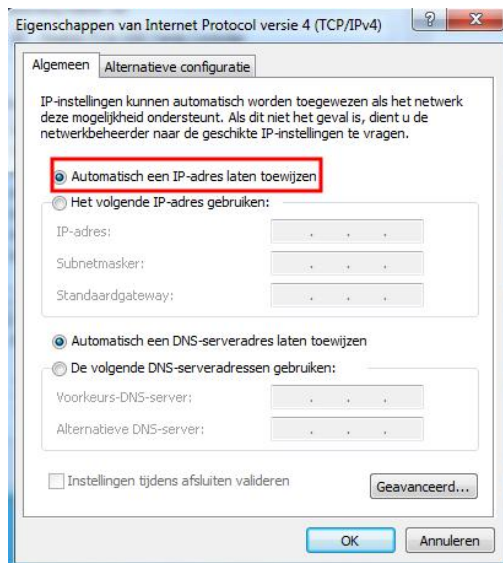

- Set a static IP address

Select "Use the following IP address" and set the correct values for the IP address, subnet mask and default gateway.

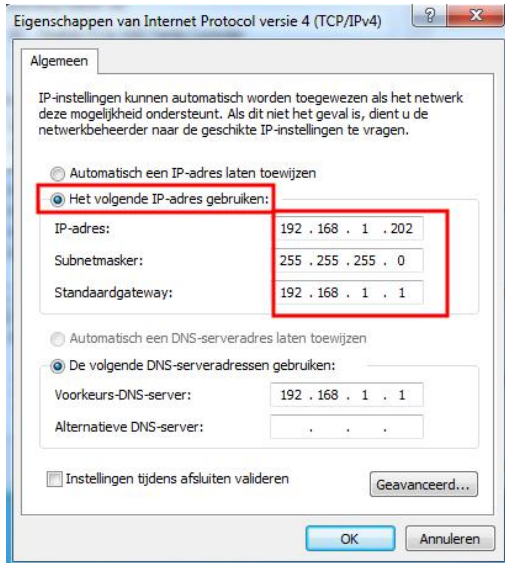

5.7.1.3 Configure Controller IP address

There are 2 ways to assign an IP address

- Assignment via built-in web page (static IP or automatic IP assignment)
- Assign via DIP switch (static IP)

DIP address selector switch definition

Switch position (ON = 1)	Value	Definition
0000 0000 --- 1111 1110	0-254	Enable the DIP selector switch assignment function and determine the value of the 3rd byte. Example: 0010 0110 (22 decimal), the IP address is "192.168.22.253".
1111 1111	255	Enable the function of specifying IP on the web page, or select the function of DHCP automatic allocation. When the IP is not allocated through the web, the IP is 192.168.1.10.

5.7.1.3.1 Configuration via Web Page

The fieldbus coupler can be set to an IP address via the "Settings > Local Settings" page after entering the page, or it can be set to be assigned automatically. Select

static address, if not set IP address, the IP is 192.168.1.10

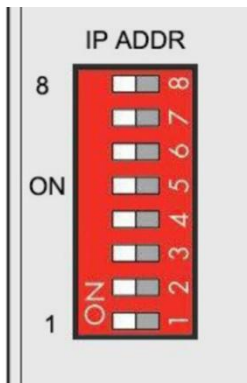

5.7.1.3.2 Assign IP via DIP Switch

Set the value of the DIP address selector switch to 0000 0000 - 1111 1110 (decimal 0 - 254), and the IP address will be assigned by the DIP switch.

The IP address consists of fixed bytes and variable bytes. The 1st, 2nd and 4th bytes are fixed bytes, the DIP selector switch determines the 3rd byte, namely:

192.168.xxx.253

The fieldbus coupler assigns an IP address via a DIP switch, and the IP address set in this way is static.

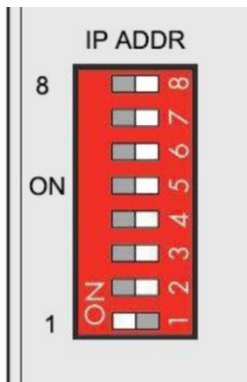

5.7.1.4 Factory Default Settings

Before logging into the web configuration page, it is necessary for you to understand the following default parameters,

Modbus TCP Server Port: 502, Modbus ID: 1

IP: Determined according to the DIP switch, if the DIP switch is 1111 1111, the default IP is 192.168.1.10

If factory default DIP switch is 0000 0000 status, then the IP is 192.168.0.253

Item	Description
Username	admin
Password	Empty

5.7.2 Login Configuration Page

- 1.Open a browser on your computer, such as IE, Chrome, etc.
- 2.Enter the IP address of the coupler node (192.168.1.10) in the address bar of the browser to enter the user login interface.



- 3.Enter "Username" and "Password" in the login interface, and then click Login.

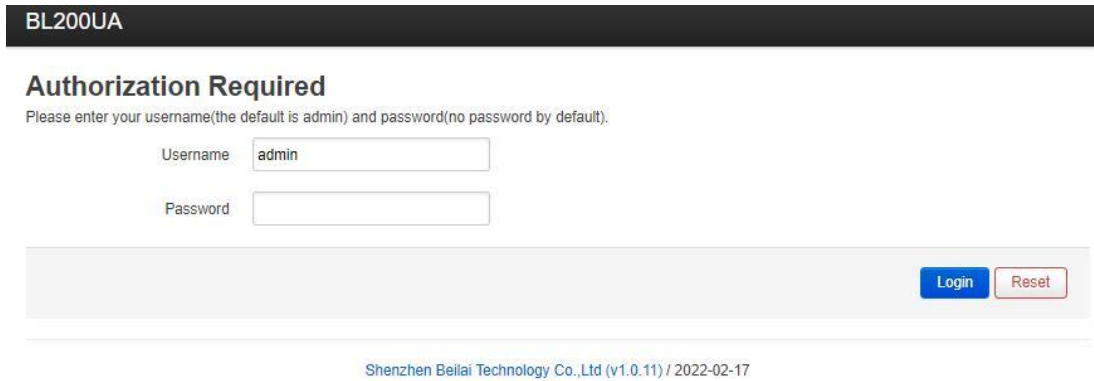

- 4.After successfully logging in to the web interface, the display is as follows

Status

System

Hostname	BL200UA
Model	BL205-OPC UA IO Module
Firmware Version	Shenzhen Beilai Technology Co.,Ltd. V1.1.12
Kernel Version	4.4.194
Local Time	2023-11-07 06:15:48
Uptime	0h 7m 27s
Load Average	0.76, 0.76, 0.43

Memory

Total Available	<div style="width: 46%;"><div style="width: 46%;"></div></div> 26.05 MB / 56.59 MB (46%)
Used	<div style="width: 46%;"><div style="width: 46%;"></div></div> 26.54 MB / 56.59 MB (46%)
Buffered	<div style="width: 6%;"><div style="width: 6%;"></div></div> 3.43 MB / 56.59 MB (6%)
Cached	<div style="width: 17%;"><div style="width: 17%;"></div></div> 9.72 MB / 56.59 MB (17%)

Network

Active Connections	<div style="width: 0%;"><div style="width: 0%;"></div></div> 125 / 16384 (0%)
--------------------	---

Shenzhen Beilai Technology Co.,Ltd (V1.1.12) / 2023-10-19

5.After configuring the parameters, you need to click the "Save and Apply" button on the page to take effect.

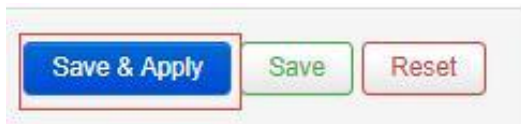

5.8 Web Configuration Page Description

5.8.1 Status

Users can check overview, system log and kernel log, as well as device parameters and device operating status.

Status > Overview

Status
Overview

System Log
Kernel Log

System

Hostname	BL200UA
Model	BL200UA-OPCUA IO Module
Firmware Version	Shenzhen Beilai Technology Co.,Ltd v1.0.11
Kernel Version	4.4.194
Local Time	2022-03-21 06:44:49
Uptime	3h 31m 35s
Load Average	0.16, 0.11, 0.09

Memory

Total Available	26.05 MB / 56.59 MB (46%)
Used	26.57 MB / 56.59 MB (46%)
Buffered	3.21 MB / 56.59 MB (5%)
Cached	9.98 MB / 56.59 MB (17%)

Network

Active Connections	22 / 16384 (0%)
--------------------	-----------------

Shenzhen Beilai Technology Co.,Ltd (v1.0.11) / 2022-02-17

Status > System Log

System Log

```

Thu Jan 1 00:00:26 1970 kern.info kernel: [ 0.000000] Booting Linux on physical CPU 0x0
Thu Jan 1 00:00:26 1970 kern.notice kernel: [ 0.000000] Linux version 4.4.194 (peng@peng) (gcc version 5.4.0 (LEDE GCC 5.4.0 unknown) ) #0 PREEMPT Sat May 9 15:23
Thu Jan 1 00:00:26 1970 kern.info kernel: [ 0.000000] CPU: ARM926EJ-S [41069265] revision 5 (ARMv5TEJ), cr=0005317f
Thu Jan 1 00:00:26 1970 kern.info kernel: [ 0.000000] CPU: VIVT data cache, VIVT instruction cache
Thu Jan 1 00:00:26 1970 kern.info kernel: [ 0.000000] Machine model: Nuvoton NUC980 IOT-GateWay Version: 0.1
Thu Jan 1 00:00:26 1970 kern.info kernel: [ 0.000000] Memory policy: Data cache writeback
Thu Jan 1 00:00:26 1970 kern.debug kernel: [ 0.000000] On node 0 totalpages: 16384
Thu Jan 1 00:00:26 1970 kern.debug kernel: [ 0.000000] free_area_init_node: node 0, pgdat c0657704, node_mem_map c3f77000
Thu Jan 1 00:00:26 1970 kern.debug kernel: [ 0.000000] Normal zone: 128 pages used for memmap
Thu Jan 1 00:00:26 1970 kern.debug kernel: [ 0.000000] Normal zone: 0 pages reserved
Thu Jan 1 00:00:26 1970 kern.debug kernel: [ 0.000000] Normal zone: 16384 pages, LIFO batch:3
Thu Jan 1 00:00:26 1970 kern.debug kernel: [ 0.000000] pcpu-alloc: s0 r0 d32768 u32768 alloc=1*32768
Thu Jan 1 00:00:26 1970 kern.debug kernel: [ 0.000000] pcpu-alloc: [0] 0
Thu Jan 1 00:00:26 1970 kern.info kernel: [ 0.000000] Built 1 zonelists in Zone order, mobility grouping on. Total pages: 16256
Thu Jan 1 00:00:26 1970 kern.notice kernel: [ 0.000000] Kernel command line: root=/dev/mtdblock2 console=ttyS0,115200n8 rdinit=/sbin/init mem=64M lpj=744448
Thu Jan 1 00:00:26 1970 kern.info kernel: [ 0.000000] PID hash table entries: 256 (order: -2, 1024 bytes)
Thu Jan 1 00:00:26 1970 kern.info kernel: [ 0.000000] Dentry cache hash table entries: 8192 (order: 3, 32768 bytes)
Thu Jan 1 00:00:26 1970 kern.info kernel: [ 0.000000] Inode-cache hash table entries: 4096 (order: 2, 16384 bytes)
Thu Jan 1 00:00:26 1970 kern.info kernel: [ 0.000000] Memory: 57756K/65536K available (4538K kernel code, 305K rvdta, 1704K rodata, 188K init, 252K bss, 7780K reser
Thu Jan 1 00:00:26 1970 kern.notice kernel: [ 0.000000] Virtual kernel memory layout:
Thu Jan 1 00:00:26 1970 kern.notice kernel: [ 0.000000] vector : 0xffff0000 - 0xffff1000 ( 4 kB)
Thu Jan 1 00:00:26 1970 kern.notice kernel: [ 0.000000] fixmap : 0xff000000 - 0xff000000 (3072 kB)
Thu Jan 1 00:00:26 1970 kern.notice kernel: [ 0.000000] vmalloc : 0xc4800000 - 0xffff0000 ( 944 MB)
Thu Jan 1 00:00:26 1970 kern.notice kernel: [ 0.000000] lowmem : 0xc0000000 - 0xc4000000 ( 64 MB)
Thu Jan 1 00:00:26 1970 kern.notice kernel: [ 0.000000] modules : 0xbf000000 - 0xc0000000 ( 16 MB)
Thu Jan 1 00:00:26 1970 kern.notice kernel: [ 0.000000] .text : 0xc0008000 - 0xc0620f54 ( 6244 kB)
Thu Jan 1 00:00:26 1970 kern.notice kernel: [ 0.000000] .init : 0xc0621000 - 0xc0650000 ( 188 kB)
Thu Jan 1 00:00:26 1970 kern.notice kernel: [ 0.000000] .data : 0xc0650000 - 0xc069c784 ( 306 kB)
Thu Jan 1 00:00:26 1970 kern.notice kernel: [ 0.000000] .bss : 0xc069c784 - 0xc06db8f8 ( 253 kB)
Thu Jan 1 00:00:26 1970 kern.info kernel: [ 0.000000] SLUB: HWalign=32, Order=0-3, MinObjects=0, CPUs=1, Nodes=1
Thu Jan 1 00:00:26 1970 kern.info kernel: [ 0.000000] Preemptible hierarchical RCU implementation.
Thu Jan 1 00:00:26 1970 kern.info kernel: [ 0.000000] Build-time adjustment of leaf fanout to 32.
Thu Jan 1 00:00:26 1970 kern.info kernel: [ 0.000000] NR_IRQS=545
Thu Jan 1 00:00:26 1970 kern.info kernel: [ 0.000000] clocksource: nuc980-timer5: mask: 0xfffff max_cycles: 0xfffff, max_idle_ns: 62215505635 ns
Thu Jan 1 00:00:26 1970 kern.info kernel: [ 0.000033] sched_clock: 24 bits at 120kHz, resolution 8333ns, wraps every 69905062489ns
Thu Jan 1 00:00:26 1970 kern.info kernel: [ 0.000741] Console: colour dummy device 80x30
Thu Jan 1 00:00:26 1970 kern.info kernel: [ 0.186616] console [ttyS0] enabled
Thu Jan 1 00:00:26 1970 kern.info kernel: [ 0.190091] Calibrating delay loop (skipped) preset value.. 148.88 BogoMIPS (lpj=744448)
Thu Jan 1 00:00:26 1970 kern.info kernel: [ 0.198174] pid_max: default: 32768 minimum: 301
Thu Jan 1 00:00:26 1970 kern.info kernel: [ 0.203133] Mount-cache hash table entries: 1024 (order: 0, 4096 bytes)
Thu Jan 1 00:00:26 1970 kern.info kernel: [ 0.209708] Mountpoint-cache hash table entries: 1024 (order: 0, 4096 bytes)
Thu Jan 1 00:00:26 1970 kern.info kernel: [ 0.218916] CPU: Testing write buffer coherency: ok
Thu Jan 1 00:00:26 1970 kern.info kernel: [ 0.224963] Setting up static identity map for 0xc400 - 0x843c
Thu Jan 1 00:00:26 1970 kern.info kernel: [ 0.271558] clocksource: jiffies: mask: 0xfffff max_cycles: 0xfffff, max_idle_ns: 19112604462750000 ns
Thu Jan 1 00:00:26 1970 kern.info kernel: [ 0.282316] futex: hash table entries: 256 (order: -1, 3072 bytes)
Thu Jan 1 00:00:26 1970 kern.info kernel: [ 0.288874] pinctrl core: initialized pinctrl subsystem
Thu Jan 1 00:00:26 1970 kern.info kernel: [ 0.296433] NET: Registered protocol family 16
Thu Jan 1 00:00:26 1970 kern.info kernel: [ 0.303199] DMA: preallocated 256 KiB pool for atomic coherent allocations
Thu Jan 1 00:00:26 1970 kern.info kernel: [ 0.316783] <DT> nuc980_d1_device_init +
Thu Jan 1 00:00:26 1970 kern.info kernel: [ 0.348016] <DT> nuc980_d1_device_init -
    
```

Status > Kernel Log

Kernel Log

```
[ 0.000000] Booting Linux on physical CPU 0x0
[ 0.000000] Linux version 4.4.194 (peng@peng) (gcc version 5.4.0 (LEDE GCC 5.4.0 unknown) ) #0 PREEMPT Sat May 9 15:23:54 2020
[ 0.000000] CPU: ARM926EJ-S [41069265] revision 5 (ARMv5TEJ), cr=0005317f
[ 0.000000] CPU: VIVT data cache, VIVT instruction cache
[ 0.000000] Machine model: Nuvoton NUC980 IOT-GateWay Version: 0.1
[ 0.000000] Memory policy: Data cache writeback
[ 0.000000] On node 0 totalpages: 16384
[ 0.000000] free_area_init_node: node 0, pgdat c0657704, node_mem_map c3f77000
[ 0.000000] Normal zone: 126 pages used for memmap
[ 0.000000] Normal zone: 0 pages reserved
[ 0.000000] Normal zone: 16384 pages, LIFO batch:3
[ 0.000000] pcpu-alloc: s0 r0 d32768 u32768 alloc=1*32768
[ 0.000000] pcpu-alloc: [0] 0
[ 0.000000] Built 1 zonelists in Zone order, mobility grouping on. Total pages: 16256
[ 0.000000] Kernel command line: root=/dev/mtblock2 console=ttyS0,115200n8 rdinit=/sbin/init mem=64M lpj=744448
[ 0.000000] PID hash table entries: 256 (order: -2, 1024 bytes)
[ 0.000000] Dentry cache hash table entries: 8192 (order: 3, 32768 bytes)
[ 0.000000] Inode-cache hash table entries: 4096 (order: 2, 16384 bytes)
[ 0.000000] Memory: 57756K/65536K available (4538K kernel code, 305K rvddata, 1704K rodata, 188K init, 252K bss, 7780K reserved, 0K cma-reserved)
[ 0.000000] Virtual kernel memory layout:
[ 0.000000] vector : 0xffff0000 - 0xffff1000 ( 4 kB)
[ 0.000000] fixmap : 0xffc00000 - 0xffff0000 (3072 kB)
[ 0.000000] vmalloc : 0xc4800000 - 0xff800000 ( 944 MB)
[ 0.000000] lowmem : 0xc0000000 - 0xc4000000 ( 64 MB)
[ 0.000000] modules : 0xbf000000 - 0xc0000000 ( 16 MB)
[ 0.000000] .text : 0xc0008000 - 0xc0620f54 (6244 kB)
[ 0.000000] .init : 0xc0621000 - 0xc0650000 ( 188 kB)
[ 0.000000] .data : 0xc0650000 - 0xc069c784 ( 306 kB)
[ 0.000000] .bss : 0xc069c784 - 0xc06db8f8 ( 253 kB)
[ 0.000000] SLUB: HWalign=32, Order=0-3, MinObjects=0, CPUs=1, Nodes=1
[ 0.000000] Preemptible hierarchical RCU implementation.
[ 0.000000] Build-time adjustment of leaf fanout to 32.
[ 0.000000] NR_IRQS:545
[ 0.000000] clocksource: nuc980-timer5: mask: 0xffffffff max_cycles: 0xffffffff, max_idle_ns: 62215505635 ns
[ 0.000033] sched_clock: 24 bits at 120kHz, resolution 8333ns, wraps every 69905062489ns
[ 0.000741] Console: colour dummy device 80x30
[ 0.186616] console [ttyS0] enabled
[ 0.190091] Calibrating delay loop (skipped) preset value.. 148.88 BogoMIPS (lpj=744448)
[ 0.198174] pid_max: default: 32768 minimum: 301
[ 0.203133] Mount-cache hash table entries: 1024 (order: 0, 4096 bytes)
[ 0.209706] Mountpoint-cache hash table entries: 1024 (order: 0, 4096 bytes)
[ 0.218916] CPU: Testing write buffer coherency: ok
[ 0.224983] Setting up static identity map for 0x8400 - 0x843c
[ 0.271558] clocksource: jiffies: mask: 0xffffffff max_cycles: 0xffffffff, max_idle_ns: 19112604462750000 ns
[ 0.282316] futex hash table entries: 256 (order: -1, 3072 bytes)
[ 0.288874] pinctrl core: initialized pinctrl subsystem
[ 0.296433] NET: Registered protocol family 16
[ 0.303199] DMA: preallocated 256 KiB pool for atomic coherent allocations
[ 0.316783] <DT> nuc980_dt_device_init +
```

5.8.2 System

5.8.2.1 System

System Properties > General Settings

The screenshot shows the 'System Properties > General Settings' page. A 'System' dropdown menu is open, listing options: System, Administration, Backup / Flash, Firmware, and Reboot. The 'General Settings' tab is active. The 'Local Time' field shows '2022/3/21 下午2:58:56' with 'Sync with browser' and 'Sync with NTP-Server' buttons. The 'Hostname' field contains 'BL200UA'. The 'Timezone' dropdown is set to 'UTC'. At the bottom right, there are three buttons: 'Save & Apply', 'Save', and 'Reset'.

Item	Description	Default
Local time	Displays the current time of the device. You can click the "Sync browser time" or "Sync with NTP server" button to update the device time.	--
Hostname	The device name can be customized to easily distinguish between multiple devices.	BL200UA
Timezone	The time zone can be selected via the drop down menu	UTC

System Properties > Logging

BL200UA
Status ▾
System ▾
Settings ▾
I/O Module ▾
Serial Module ▾
OPC UA ▾
Operation&Control ▾
Logout
REFRESHING

System

Here you can configure the basic aspects of your device like its hostname or the timezone.

System Properties

General Settings
Logging
Time Synchronization
Language and Style

System log buffer size:
 KiB

External system log server:

External system log server port:

External system log server protocol:

Write system log to file:

Log output level:

Cron Log Level:

Save & Apply ▾
Save
Reset

Shenzhen Beilai Technology Co.,Ltd (v1.0.11) / 2022-02-17

Item	Description	Default
System log buffer size		64
External system log server		
External system log server port		
External system log server protocol		
Write system log to file		
Log output level		
Cron log level		

System Properties > Time Synchronization

An NTP server can be set to synchronize time

BL200UA [Status](#) [System](#) [Settings](#) [I/O Module](#) [Serial Module](#) [OPC UA](#) [Operation&Control](#) [Logout](#) [REFRESHING](#)

System

Here you can configure the basic aspects of your device like its hostname or the timezone.

System Properties

[General Settings](#) [Logging](#) [Time Synchronization](#) [Language and Style](#)

Enable NTP client

Provide NTP server

Use DHCP advertised servers

NTP server candidates

0.openwrt.pool.ntp.org	x
1.openwrt.pool.ntp.org	x
2.openwrt.pool.ntp.org	x
3.openwrt.pool.ntp.org	x
	+

[Save & Apply](#) [Save](#) [Reset](#)

Shenzhen Beilai Technology Co.,Ltd (v1.0.11) / 2022-02-17

System Properties > Language and Style

BL200UA [Status](#) [System](#) [Settings](#) [I/O Module](#) [Serial Module](#) [OPC UA](#) [Operation&Control](#) [Logout](#) [REFRESHING](#)

System

Here you can configure the basic aspects of your device like its hostname or the timezone.

System Properties

[General Settings](#) [Logging](#) [Time Synchronization](#) [Language and Style](#)

Language

Design

[Save & Apply](#) [Save](#) [Reset](#)

Shenzhen Beilai Technology Co.,Ltd (v1.0.11) / 2022-02-17

Item	Description	Default
Language	Available in auto, English, Chinese	auto
Design	Currently only Bootstrap is supported.	Bootstrap

5.8.2.2 Administration

Administration > Router Password

Change the administrator password for accessing the device.

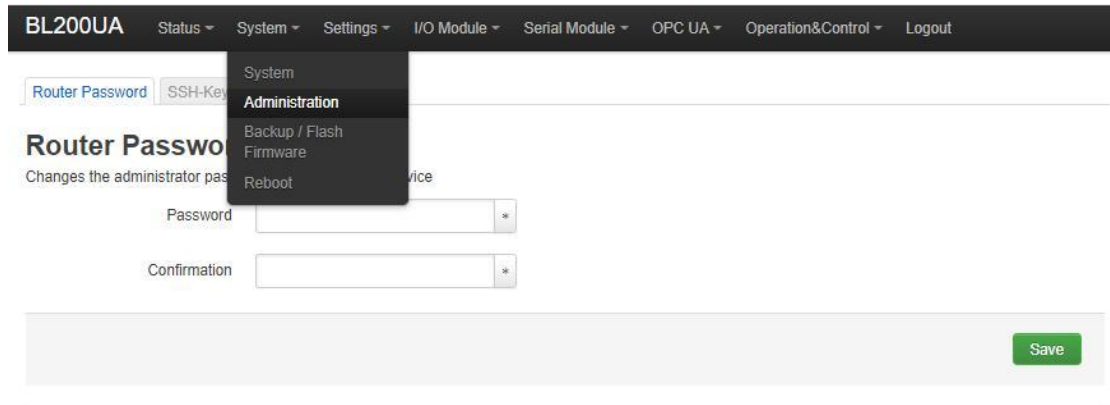

Shenzhen Beilai Technology Co.,Ltd (v1.0.11) / 2022-02-17

Administration > SSH Keys

Public keys allow for the passwordless SSH logins with a higher security compared to the use of regular passwords. In order to upload a new key to the device, paste an OpenSSH compatible public key line or drag a .pub file into the input field.



Shenzhen Beilai Technology Co.,Ltd (v1.0.11) / 2022-02-17

5.8.2.3 Backup/Flash Firmware

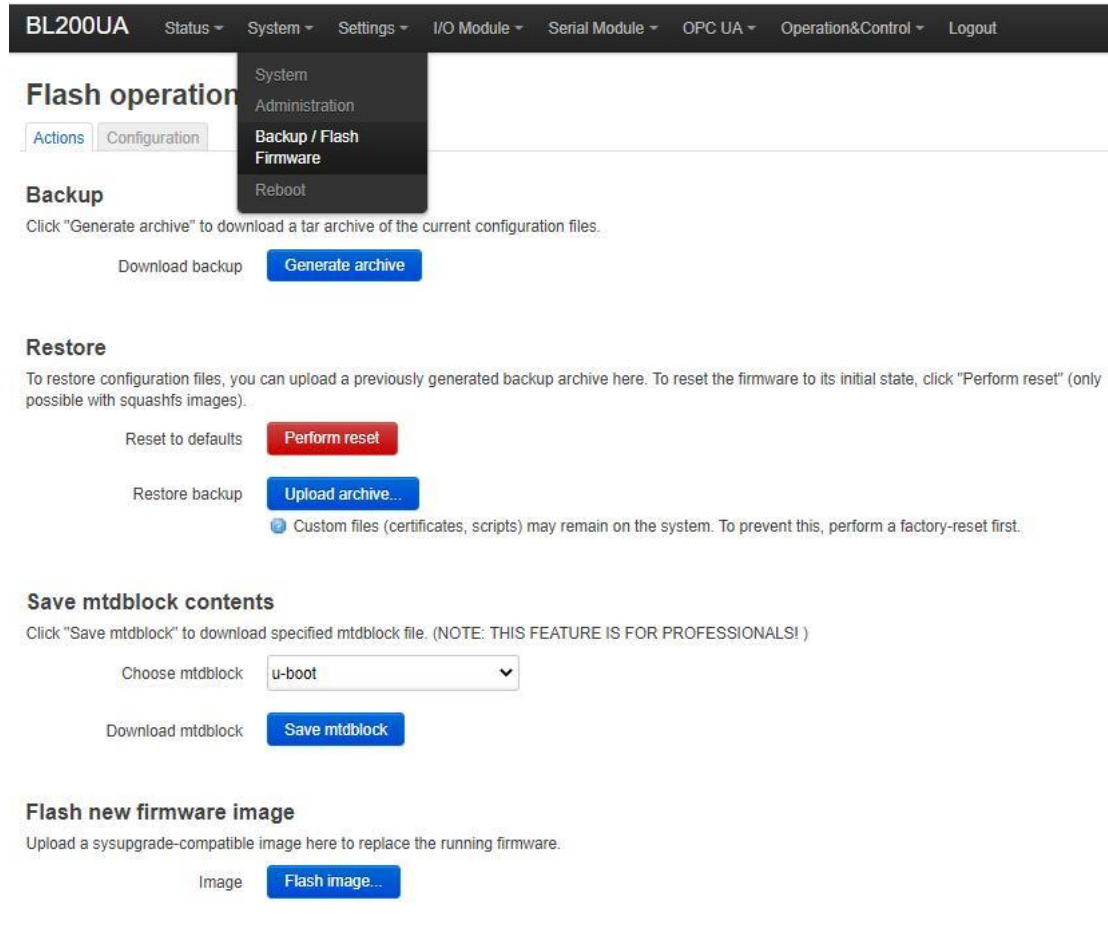

Flash operation

System
Administration
Backup / Flash Firmware
Reboot

Backup

Click "Generate archive" to download a tar archive of the current configuration files.

Download backup

Restore

To restore configuration files, you can upload a previously generated backup archive here. To reset the firmware to its initial state, click "Perform reset" (only possible with squashfs images).

Reset to defaults

Restore backup

Custom files (certificates, scripts) may remain on the system. To prevent this, perform a factory-reset first.

Save mtddblock contents

Click "Save mtddblock" to download specified mtddblock file. (NOTE: THIS FEATURE IS FOR PROFESSIONALS!)

Choose mtddblock

Download mtddblock

Flash new firmware image

Upload a sysupgrade-compatible image here to replace the running firmware.

Image

Shenzhen Beilai Technology Co.,Ltd (v1.0.11) / 2022-02-17

Item	Description	Default
Backup	Click "Generate archive" to download a tar archive of the current configuration files.	--
Restore	To restore configuration files, you can upload a previously generated backup archive here. To reset the firmware to its initial state, click "Perform reset" (only possible with squashfs images).	--
Save mtddblock	Click "Save mtddblock" to download specified mtddblock file. (NOTE: THIS FEATURE IS FOR PROFESSIONALS)	--
Flash image	Upload a sysupgrade-compatible image here to replace the running firmware.	--

5.8.2.4 Reboot

Click "Perform reboot" will reboot your device

BL200UA Status ▾ System ▾ Settings ▾ I/O Module ▾ Serial Module ▾ OPC UA ▾ Operation&Control ▾ Logout

Reboot

Reboots the operating system of your device

[Perform reboot](#)

Shenzhen Beilai Technology Co.,Ltd (v1.0.11) / 2022-02-17

5.8.3 Settings

BL200UA Status ▾ System ▾ Settings ▾ I/O Module ▾ Serial Module ▾ OPC UA ▾ Operation&Control ▾ Logout

Device settings

Device settings

Modbus Device ID:
• If not set or set to 0, the device ID in the Modbus command is ignored

Modbus TCP port:

Dial switch address: 192.168.1.253
• The 3rd segment of IP address is determined by dial switch, restart the device and the modification will take effect

IP Address Type: ▾

Set device IP address:

Subnet Mask:

Gateway address:

[Save & Apply](#) ▾ [Save](#) [Reset](#)

Shenzhen Beilai Technology Co.,Ltd (v1.0.11) / 2022-02-17

Item	Description	Default
Modbus Device ID	Modbus device ID range is 1~247.	1
Modbus TCP port	Modbus TCP protocol port number, which can be customized.	502
DIP switch address	Displays the IP address set by the DIP switch.	
IP address type	Select from "Static Address", "Dynamic Address(DHCP)".	
Set device IP address	The IP address of the device can be set by yourself, and it needs to be restarted to take effect after setting.	--

Subnet mask	Set IP subnet mask	
Gateway address	Set IP gateway address	

5.8.4 I/O Modules

After power on, the controller automatically recognizes all I/O modules connected to it and creates an internal local process image based on the module type, data width and the module's position in the node.

If I/O modules are added, changed or removed, a new process image is created and the process data addresses change. When adding an I/O module, the process data of all previous I/O modules must be considered.

The controller can connect up to 32 I/O modules, including digital input and output, analog input and output and special function modules.

BL200UA								
Status - System - Settings - I/O Module - Serial Module - OPC UA - Operation&Control - Logout								
IO status								
IO Slot	Module Name	Module Type	Channel Number	Modbus Address	24V Address-State	Soft Version	IO Status	Channel Status
1	M1081	DI	8	2000-2007	9001-Power On	5	Normal	Channel Status
2	M2082	DO	8	1000-1007	9002-Power On	5	Normal	Channel Status
3	M3041	AI	4	3000-3006	9003-Power On	5	Normal	Channel Status
4	M4044	AO	4	4000-4006	9004-Power On	5	Normal	Channel Status
5	M6021	COM	2	0-0	9005-Power On	5	Normal	Channel Status

Shenzhen Beilai Technology Co.,Ltd (v1.0.11) / 2022-02-17

Item	Description
IO slot	The order of IO modules in the slot, the first module card position close to the controller is 1, and the following ones are 2 3 4...
Module name	I/O module model
Module type	I/O module function type
Channel Number	Data width of I/O module
Modbus Address	Process map address of the I/O module inside the controller
24V Address State	Power supply status on the field side of the I/O module, digital, 1 bit
Software	I/O module internal firmware version

version	
IO status	I/O module and controller communication status
Channel status	Click to view and set the parameters of different types of I/O modules

5.8.4.1 Digital Input Module

The digital input module can provide two types of data, one is the current input state value, Boolean type; the other is the counter value, 32-bit numerical type, which supports the clear function.

IO status

IO Slot:1,Module Type:DI,Module Name:M1081

Channels	Modbus Address	Value
1	2000	Open
2	2001	Open
3	2002	Open
4	2003	Open
5	2004	Open
6	2005	Open
7	2006	Open
8	2007	Open

Fiter Time

Fiter Time(ms)

DI Count

Channels	Modbus Address	Value	Conut Mode	Clear
1	5000	0	Rising Edge <input type="button" value="v"/>	<input type="button" value="Clear"/>
2	5002	0	Rising Edge <input type="button" value="v"/>	<input type="button" value="Clear"/>
3	5004	0	Rising Edge <input type="button" value="v"/>	<input type="button" value="Clear"/>
4	5006	0	Rising Edge <input type="button" value="v"/>	<input type="button" value="Clear"/>
5	5008	0	Rising Edge <input type="button" value="v"/>	<input type="button" value="Clear"/>
6	5010	0	Rising Edge <input type="button" value="v"/>	<input type="button" value="Clear"/>
7	5012	0	Rising Edge <input type="button" value="v"/>	<input type="button" value="Clear"/>
8	5014	0	Rising Edge <input type="button" value="v"/>	<input type="button" value="Clear"/>

Item	Description
Channels	Channel number of the digital input module
Modbus Address	Process map address of Boolean status data inside the controller
Value	Display the current input state, open: logic 0, close: logic 1
Fliter Time	Selecting the time for DI filtering

Item	Description
Channels	Channel number of the digital input module
Modbus Address	Process map address of the count value inside the controller
Value	Display the current input count value, 32-bit unsigned integer
Count Mode	Selection of "Rising Edge", "Falling Edge", "Rising Edge and Falling Edge" Trigger Counting Methods
Clear	Clear the current channel counter value

5.8.4.2 Digital Output Module

BL200UA
Status ▾
System ▾
Settings ▾
I/O Module ▾
Serial Module ▾
OPC UA ▾
Operation&Control ▾
Logout

IO status

IO Slot:2,Module Type:DO,Module Name:M2082

Channels	Modbus Address	Value	PowerOn Status	Open/Close
1	1000	Open	Open ▾	Open/Close
2	1001	Open	Open ▾	Open/Close
3	1002	Open	Open ▾	Open/Close
4	1003	Open	Open ▾	Open/Close
5	1004	Open	Open ▾	Open/Close
6	1005	Open	Open ▾	Open/Close
7	1006	Open	Open ▾	Open/Close
8	1007	Open	Open ▾	Open/Close

Back to Overview
Save & Apply ▾
Save
Reset

Shenzhen Beilai Technology Co.,Ltd (v1.0.11) / 2022-02-17

Item	Description
Channels	Channel number of the digital output module

Modbus Address	Process map address of the digital output boolean data inside the controller
Value	Display the current output state, open: 0, close: 1
Power-on status	Set the state of DO after power-on, select from "open", "close", "last"
Open/Close	Can control the current channel output state

5.8.4.3 Analog Input Module

The analog input (AI) type module supports setting parameters through the controller web page, so that the data conversion is automatically realized inside the module, and the actual engineering value corresponding to the sensor can be directly output.

BL200
Status ▾
System ▾
Settings ▾
I/O Module ▾
Serial Module ▾
Operation Control ▾
Logout

IO status

IO Slot:4,Module Type:AI,Module Name:M3041

Channels	Modbus Address	Value	Mode	Min Value	Max Value	Offset(mA)
1	3000	4.000000	Current 4-20mA ▾	<input type="text"/>	<input type="text"/>	<input type="text"/>
2	3002	4.000000	Current 4-20mA ▾	<input type="text"/>	<input type="text"/>	<input type="text"/>
3	3004	4.000000	Current 4-20mA ▾	<input type="text"/>	<input type="text"/>	<input type="text"/>
4	3006	4.000000	Current 4-20mA ▾	<input type="text"/>	<input type="text"/>	<input type="text"/>

Back to Overview

Save & Apply
▾
Save
Reset

Shenzhen Beilai Technology Co.,Ltd (V1.1.12) / 2023-10-19

Item	Description
Channels	Channel number of the analog input module
Modbus Address	Process map address of the analog input module inside the controller
Value	Display the actual engineering value input by the current channel, 32-bit single-precision floating-point type
Mode	Different models of analog input modules have different options, please refer to the specific analog input I/O module manual for details.
Min Value	Sensor range minimum
Max Value	Sensor range maximum

Offset(mA)	The offset allows you to adjust the error between acquisition and actual.
------------	---

There is a linear relationship between the electrical signal value of the analog input module (usually a sensor) and the actual engineering value. Their formulas are as follows (take 4-20mA as an example):

Actual engineering value = (current value - 4) * ((maximum - minimum) / (20 - 4)) + minimum

Take the 4-20mA type water level sensor to measure the depth of the water tower as an example:

The known water level sensor range is 0-100m, the current data is 5.6mA, and the depth of the water tower is calculated:

Into the formula:

$$(5.6 - 4) * ((100 - 0) / (20 - 4)) + 0 = 10$$

The depth of the water tower is 10m

5.8.4.4 Analog Output Module

BL200
 [Status](#) ▾
 [System](#) ▾
 [Settings](#) ▾
 [I/O Module](#) ▾
 [Serial Module](#) ▾
 [Operation Control](#) ▾
 [Logout](#)

IO status

IO Slot:7,Module Type:AO,Module Name:M4041

Channels	Modbus Address	Value	Mode	Min Value	Max Value	Set Value
1	4000	4.000000	Current 4-20mA ▾	<input type="text"/>	<input type="text"/>	<input type="text"/>
2	4002	4.000000	Current 4-20mA ▾	<input type="text"/>	<input type="text"/>	<input type="text"/>
3	4004	4.000000	Current 4-20mA ▾	<input type="text"/>	<input type="text"/>	<input type="text"/>
4	4006	4.000000	Current 4-20mA ▾	<input type="text"/>	<input type="text"/>	<input type="text"/>

Back to Overview

Save & Apply ▾
Save
Reset

Shenzhen Beilai Technology Co.,Ltd (V1.1.12) / 2023-10-19

Item	Description
Channels	Channel number of the analog output module
Modbus Address	Process map address of the analog output module inside the controller
Value	Display the actual engineering value output by the current channel, 32-bit single-precision floating-point type

Mode	Different models of analog output modules have different options, please refer to the specific analog output I/O module manual for details.
Min value	Actual engineering value minimum value
Max value	Actual engineering value maximum value
Set value	You can set the actual project value required for the output

5.8.5 Serial Port Module

Various sensors, meters and other devices that support Modbus RTU(Master) protocol can be connected to the edge controller through the serial port module. It allows process mapping between external sensor data and the coupler via the local bus.

5.8.5.1 Serial Port Settings

BL200UA
Status ▾
System ▾
Settings ▾
I/O Module ▾
Serial Module ▾
OPC UA ▾
Operation&Control ▾
Logout

Serial Settings

Serial Settings

IO Slot	Module Type	COM Type	COM Name	Baudrate	Data bits	Parity	Stop bits	Modbus Settings
5	M6021	RS485	COM1	9600 ▾	8 ▾	None ▾	1 ▾	Modbus Settings
5	M6021	RS485	COM2	9600 ▾	8 ▾	None ▾	1 ▾	Modbus Settings

Save & Apply ▾
Save
Reset

Shenzhen Beilai Technology Co.,Ltd (v1.0.11) / 2022-02-17

5.8.5.2 Modbus Settings

Modbus settings are used to add Modbus RTU devices to the serial communication I/O module. A maximum of 25 Modbus commands can be created.

Modbus Master

Modbus Master

Name	Alias	Slave Interface	Slave Address	Function Code	Data Type	Register Start Address	Data Number	Mapping Address	Enable	Query
This section contains no values yet										
<input style="width: 100px;" type="text"/> <input type="button" value="Add"/>										
<input type="button" value="Save & Apply"/> <input type="button" value="Save"/> <input type="button" value="Reset"/>										

Shenzhen Beilai Technology Co., Ltd (v1.0.11) / 2022-02-17

Enter the custom data name in the input box and click Add

Modbus Master

Modbus Master

Name	Alias	Slave Interface	Slave Address	Function Code	Data Type	Register Start Address	Data Number	Mapping Address	Enable	Query
This section contains no values yet										
<input style="width: 100px;" type="text"/> <input type="button" value="Add"/>										
<input type="button" value="Save & Apply"/> <input type="button" value="Save"/> <input type="button" value="Reset"/>										

Shenzhen Beilai Technology Co., Ltd (v1.0.11) / 2022-02-17

The configuration box pops

Modbus Master - 1

Alias

Slave Interface ▾

Slave Address

Function Code ▾

Register Start Address

Data Number

Mapping address alloc ▾

Polling period(s)

🔊 If not set, the default is 0.2s

Response timeout(s)

🔊 If not set, the default is 0.5s

Item	Description
Alias	Device nickname can be used to distinguish data
Slave Interface	Select serial channel
Slave address	Slave device address, range 1-247
Function code	Select according to the slave data type, including: "01", "02", "03", "04"
Register start address	Register start address of slave data
Data number	Number of slave data
Mapping address alloc	Support distribution method: auto According to different data types, the system automatically allocates down the starting address of the mapping, and the addresses are continuous. manual Manual allocation allows mapping addresses to be allocated across segments
Polling period (s)	The interval between two adjacent polling commands
Response timeout (s)	After sending the command to the slave, wait for the maximum time for the slave to return data. If the time exceeds this time, the slave will be considered to have no response.

You can modify, delete, and view data of slave, or you can disable collection.

BL200UA
Status ▾
System ▾
Settings ▾
I/O Module ▾
Serial Module ▾
OPC UA ▾
Operation&Control ▾
Logout

Modbus Master

Modbus Master

Name	Alias	Slave Interface	Slave Address	Function Code	Data Type	Register Start Address	Data Number	Mapping Address	Enable	Query
1	1	COM1	1	1	Bool	0	1	10000-10000	<input checked="" type="checkbox"/>	<div style="border: 1px solid #ccc; padding: 5px; display: inline-block;"> Query <input type="button" value="Edit"/> <input type="button" value="Delete"/> </div>

Shenzhen Beilai Technology Co.,Ltd (v1.0.11) / 2022-02-17

5.8.6 Operation and Control

5.8.6.1 Arithmetic Operation

BL200
Status ▾
System ▾
Settings ▾
I/O Module ▾
Serial Module ▾
Operation Control ▾
Logout

Arithmetic operation
Logical operation
Condition operation

Arithmetic operation

Arithmetic operation

50000-50014 addresses are used to save intermediate calculation results, which can be published through mqtt or read through MODBUS

Name	Input1	Operation	Input2	Operation	Input3	Output Address	Output Value
This section contains no values yet.							

Add

Save & Apply ▾
Save
Reset

Shenzhen Beilai Technology Co.,Ltd (V1.1.12) / 2023-10-19

Arithmetic operation - 1

Input1

Operation

Input2

Operation

Input3

Output Address

Publish

Dismiss
Save

It supports "addition, subtraction, multiplication, and division" operations between AI, AO, or RS485 slave numerical data, and can also perform operations with "addition, subtraction, multiplication, and division" constants, and freely match 1 or 2 conditions to combine the output results. If a 16-bit register address is used as the output result, the output with a decimal is an integer.

5.8.6.2 Logical Operation

BL200
Status ▾
System ▾
Settings ▾
I/O Module ▾
Serial Module ▾
Operation Control ▾
Logout

Arithmetic operation
Logical operation
Condition operation

Logical operation

Bool Logic

Name	Input1	Condition	Relationship	Input2	Condition	Output Address	Output Value	Logic Value
<i>This section contains no values yet</i>								
<input style="width: 100px; height: 20px;" type="text"/> Add								

Numerical Logic

Name	Input1	Condition	Threshold	Relationship	Input2	Condition	Threshold	Output Address	Output Value	Logic Value
<i>This section contains no values yet</i>										
<input style="width: 100px; height: 20px;" type="text"/> Add										

Combinational logic

Name	Input1	Condition	Relationship	Input2	Condition	Output Address	Output Value	Logic Value
<i>This section contains no values yet</i>								
<input style="width: 100px; height: 20px;" type="text"/> Add								

Save & Apply ▾
Save
Reset

Shenzhen Beilai Technology Co.,Ltd (V1.1.12) / 2023-10-19

Bool logic configuration

Logical operation - 1

Input1 REG1000

Condition Open

Relationship Logic And

Input2 REG1000

Condition Open

Output Type Bool Type

Output Address -- Please choose --

Bool Value Open

Output Delay(ms)

Set Default

Dismiss Save

Numerical Logic Configuration

Logical operation - 1

Input1 REG3000

Condition Greater Than(>)

Threshold

Relationship Logic And

Input2 REG3000

Condition Greater Than(>)

Threshold

Output Type Bool Type

Output Address -- Please choose --

Bool Value Open

Output Delay(ms)

Set Default

Dismiss Save

Combinational logic configuration

Logical operation - 3

Input1	<input type="text" value="1"/>
Condition	<input type="text" value="Is true"/>
Relationship	<input type="text" value="Logic And"/>
Input2	<input type="text" value="2"/>
Condition	<input type="text" value="Is true"/>
Output Type	<input type="text" value="Bool Type"/>
Output Address	<input type="text" value="-- Please choose --"/>
Bool Value	<input type="text" value="Open"/>
Output Delay(ms)	<input type="text"/>
Set Default	<input type="checkbox"/>

Dismiss

Save

Users can freely set various combination linkages between I/O (digital input and output, analog input and output) or serial port modules (Modbus slave data) according to needs. Whether the built logic is triggered can be judged according to the logic value item of the web page, "0" means not triggered, and "1" means triggered. Logical value items cannot be updated automatically, and the web page must be manually refreshed.

Example:

Logic 1 (And), input condition A and input condition B meet the trigger condition at the same time, output result Y.

Logic 2 (Or), any one of input condition C or input condition D satisfies the trigger condition, and the output result is Y.

Logic 3: Logic 1 + Logic 2 can be combined to form a logic 3 or more combinations.

5.8.6.3 Condition Operation

BL200
Status ▾
System ▾
Settings ▾
I/O Module ▾
Serial Module ▾
Operation Control ▾
Logout

Arithmetic operation
Logical operation
Condition operation

Condition operation

Condition operation
50000-50014 addresses are used to save intermediate calculation results, which can be published through mqtt or read through MODBUS

Name	Condition(True)	Input1	Operation	Input2	Operation	Input3	Output Address	Output Value
<i>This section contains no values yet</i>								

Add

Save & Apply ▾
Save
Reset

Shenzhen Beilai Technology Co.,Ltd (V1.1.12) / 2023-10-19

Condition operation - 1

Condition(True)

Input1

Operation

Input2

Operation

Input3

Output Address

Publish

Dismiss
Save

Conditional operation is based on arithmetic operation plus condition triggering, that is, when the condition is satisfied, AI, AO or RS485 slave numerical type data or constants, these data can be free to choose 1-3 conditions for each other to "add, subtract, multiply or divide" arithmetic operation.

5.8.6.4 Example

✧ Take a simple packing system as an example

Requirements:

(1) After pressing the start button, the conveyor belt B starts to run first, and drags the empty box forward to the designated position. After reaching the designated position,

SQ2 sends a signal to stop the conveyor belt B from running.

(2) After the conveyor belt B stops, the conveyor belt A starts to run, and the products fall into the boxes one by one. The SQ1 sensor detects the products and detects that the products fall into the box. Conveyor belt A stops running, conveyor belt B starts running, and it goes on and on, until the stop button is pressed, and conveyor belts A and B stop at the same time.

To realize such a function in S7-200SMART, the peripheral wiring needs to use DI and DQ as follows:

Input		Output	
I0.0	Automatic control button	Q0.1	Conveyor A output
I0.1	Stop button	Q0.2	Conveyor B output
I0.2	B conveyor belt moving		
I0.3	A conveyor belt moving		
I0.4	SQ2 input		
I0.5	SQ1 input		

Using BL205 calculation and control simulation to achieve such requirements, the DI and DO required for wiring are as follows:

Input		Output	
DI1	A conveyor belt moving	DO1	Conveyor A output
DI2	B conveyor belt moving	DO2	Conveyor B output
DI3	Stop button		
DI4	Automatic control button		
DI5	Detect empty box sensor, SQ2 input		
DI6	Detect product SQ1 input		

5.8.6.4.1 Bool Logic Configuration Example

BL200Pro

[Status](#) [System](#) [Settings](#) [I/O Module](#) [Serial Module](#) [OPC UA](#) [Operation Control](#) [Cloud platform](#) [Logout](#)

Arithmetic operation | Logical operation | Condition operation

Logical operation

Bool Logic

Name	Input1	Condition	Relationship	Input2	Condition	Output Address	Output Value	Logic Value	
Achuansongdai	REG2000	close	None	none	none	REG1000	close	0	Edit Delete
Bchuansongdai	REG2001	close	None	none	none	REG1001	close	0	Edit Delete
tingzi	REG2002	close	None	none	none	REG1000,REG1001...	Open	0	Edit Delete
zidongB	REG2003	close	None	none	none	REG1001	close	0	Edit Delete
kongzixiang	REG2004	close	None	none	none	REG1000	close	0	Edit Delete
Btingzi	REG2004	close	None	none	none	REG1001	Open	0	Edit Delete
changping	REG2005	close	None	none	none	REG1001	close	0	Edit Delete
Atingzi	REG2005	close	None	none	none	REG1000	Open	0	Edit Delete

[Add](#)

Logical operation - Achuansongdai

Input1:

Condition:

Relationship:

Output Type:

Output Address: ✖

-- Please choose --

Bool Value:

Output Delay(ms):

Set Default:

Dismiss Save

Steps:

- (1) Enter Achuansongdai, click Add, and the configuration box will pop up.
- (2) Enter 1: Select DI1 register REG2000.
- (3) Condition: Select Close.

- (4) Relationship: Select "None", because DI1 directly controls the operation of A conveyor belt, so select "None" because there are no other conditions.
- (5) Output type: Select Bool type, because DO1 control is Bool.
- (6) Output address: REG1000, DI1 only controls one DO1, so only select the DO1 register address, if DI controls multiple registers, you can select multiple registers. As in the third logic "tingzi", press the stop button, both conveyor belts A and B stop.
- (7) Bool value: Off, DI1 controls DO1 to close, so choose to close.
- (8) Output delay (milliseconds): Since it is a timely response and no delay is required, leave it blank.
- (9) Set default: When the selection logic is not established, whether DO1 restores the default state, select according to the requirements.
- (10) Click "Save".
- (11) Follow the same steps to build other logic.
- (12) Click "Save and Apply" to write into the BL205 controller.

5.8.6.4.2 Numerical Logic Configuration Example

The AI1 register REG3000 is connected to the temperature sensor to monitor the temperature of the motor. When the collected temperature is greater than 50, the fan is turned on, and the fan is controlled by the DO3 register REG1002.

Numerical Logic

Name	Input1	Condition	Threshold	Relationship	Input2	Condition	Threshold	Output Address	Output Value	Logic Value	
wendu	REG3000	Greater Than	50	None	none	none	none	REG1002	close	0	Edit Delete
<input style="width: 100%; height: 20px; border: 1px solid #ccc;" type="text"/> Add											

Logical operation - wendu

Input1: REG3000

Condition: Greater Than(>)

Threshold: 50

Relationship: None

Output Type: Bool Type

Output Address: REG1002

Bool Value: Close

Output Delay(ms):

Set Default:

Similarly, numerical logic and Bool logic have the same logic principle. Numerical logic only judges that the condition is "greater than", "less than" or "equal to" a certain value as a linkage condition.

5.8.6.4.3 Combinational Logic Example

The conveyor belt is not running, the temperature of the motor exceeds 50 degrees, the fan is turned on, and the alarm DO4 register REG1003 is triggered.

Combinational logic

Name	Input1	Condition	Relationship	Input2	Condition	Output Address	Output Value	Logic Value	
bj	zidongB	Is false	Logic And	wendu	Is true	REG1003	close	0	<input type="button" value="Edit"/> <input type="button" value="Delete"/>
<input type="text"/> <input type="button" value="Add"/>									

Logical operation - bj

Input1

Condition

Relationship

Input2

Condition

Output Type

Output Address

Bool Value

Output Delay(ms)

Set Default

Dismiss

Save

Steps:

- (1) In the Combinational Logic item, input the name "bj", click Add, and the configuration box will pop up.
- (2) Input 1: Select the logic name "zidongB" built in Bool logic before, you can choose Bool logic or numerical logic according to your demand.
- (3) Condition: Select "Is false", according to your demand, whether the logic selected by input 1 is triggered or not as a condition.
- (4) Relationship: Select "Logic And" to choose, according to your demand, the logical relationship between condition 1 and condition 2, you can also select "no" condition 2.
- (5) Input 2: Select the logic name "wendu", choose Bool logic or numerical logic according to your demand.
- (6) Condition: Select "Is true", according to your demand, whether the logic selected by input 2 is triggered or not as a condition.
- (7) Output Type: Select "Bool Type", select Bool or numeric data according to "Output Address".
- (8) Output address: Select the register address to be operated. DO4 register REG1003.
- (9) Bool value: Close, DO4 closed to control the alarm
- (10) Output delay (milliseconds): It is a timely response, there is no need for a delay, so do not fill in.
- (11) Set default: Choose whether to restore the default state of DO4 when the logic is not valid, according to your demand.

- (12) Click "Save".
- (13) Click "Save and Apply" to write into BL205 controller.

5.8.6.4.4 Arithmetic Operation Configurations

The sensor collects the quantity produced in a day and stores it in register REG40002, and through the arithmetic function it calculates the quantity produced in each hour of an 8-hour day and stores it in register REG40004, and the data in register REG40004 can be sent to your platform or server through OPC UA .

BL200Pro

Status ▾ System ▾ Settings ▾ I/O Module ▾ Serial Module ▾ OPC UA ▾ Operation Control ▾ Cloud platform ▾ Logout

Arithmetic operation
Logical operation
Condition operation

Arithmetic operation

Arithmetic operation

50000-50014 addresses are used to save intermediate calculation results, which can be published through mqtt or read through MODBUS

Name	Input1	Operation	Input2	Operation	Input3	Output Address	Output Value	
shengchanxiaolv	REG4002	/	8	+	none	REG4004	0	Edit Delete

Add

Save & Apply ▾
Save
Reset

Shenzhen Beilai Technology Co.,Ltd (V1.1.9) / 2023-07-14

Arithmetic operation - shengchanxiaolv

Input1 REG4002 ▾

Operation / ▾

Input2 Constant ▾

Input2 8

Operation + ▾

Input3 None ▾

Output Address REG4004 ▾

Publish

Dismiss
Save

Steps

- (1) Enter the name "shengchanxiaolv", click Add, and a configuration box will pop up.
- (2) Input 1: Select the yield register REG40002.
- (3) Operation: Select "/", you can select "add, subtract, multiply and divide" here

according to your demand.

(4) Input 2: Select Constant, you can select other register address according to your demand.

(5) Input 2: Fill in the constant because constant is selected, when select a register, there is no such item.

(6) Operation: According to whether there is also a condition 3 selection, if not, then it doesn't matter.

(7) Input 3: Select "none", because there is no need for this condition option, you can also choose registers, constants, none.

(8) Output Address: Select the register address to store the result of the operation.

(9) Click "Save".

(10) Click "Save and Apply" to write into the BL205 controller.

5.8.7 OPC UA

After configuring the OPC UA parameters, click "Save and Apply" to send them to the BL205 controller to take effect.

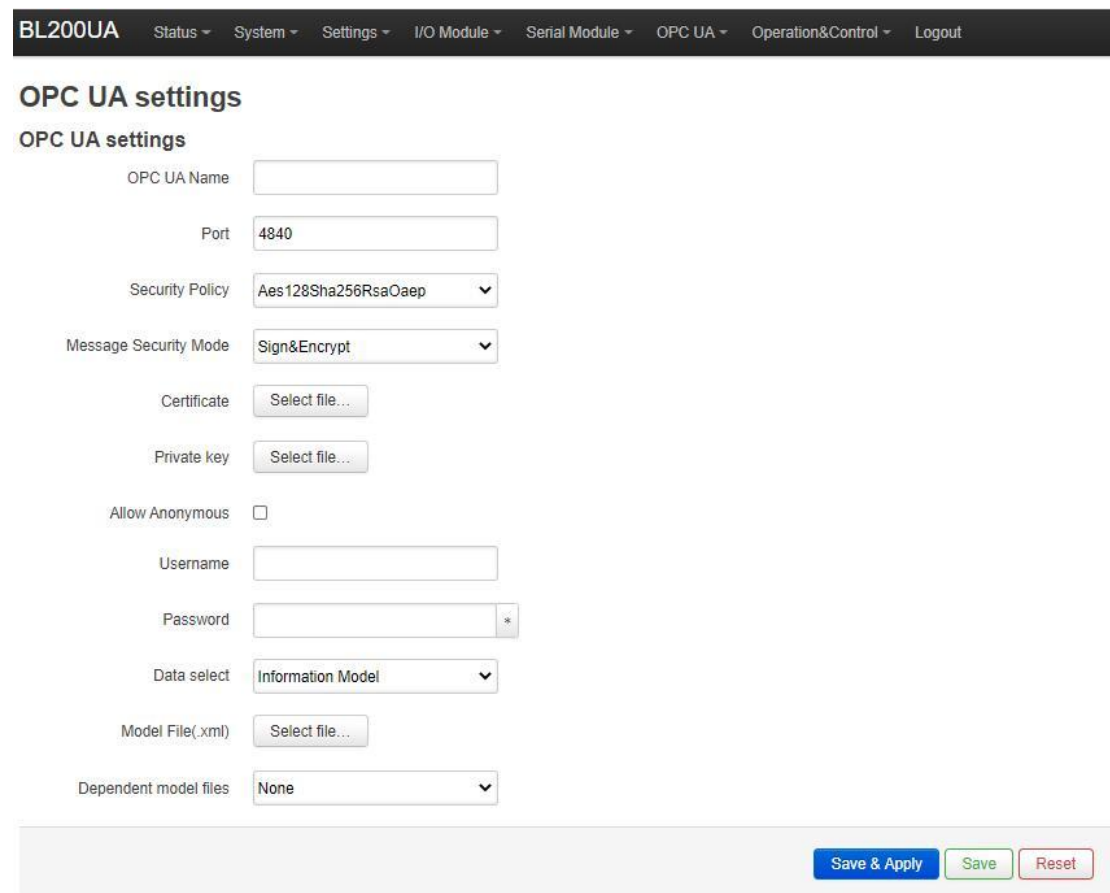

The screenshot shows the web interface for configuring OPC UA settings on a BL200UA controller. The navigation bar at the top includes: BL200UA, Status, System, Settings, I/O Module, Serial Module, OPC UA, Operation&Control, and Logout. The main heading is "OPC UA settings". The configuration fields are as follows:

- OPC UA Name:
- Port:
- Security Policy:
- Message Security Mode:
- Certificate:
- Private key:
- Allow Anonymous:
- Username:
- Password:
- Data select:
- Model File(.xml):
- Dependent model files:

At the bottom right, there are three buttons: "Save & Apply" (blue), "Save" (green), and "Reset" (red).

Item	Description	Default
OPC UA name	OPC UA server name	
Port	OPC UA server port number	4840
Security policy	None basic128rsa15 basic256 basic256sha256 aes128sha256rsaoaep All security policies	None
Message security mode	Sign Sign and encrypt	
Certificate	OPC UA certificate, click the uploaded certificate to load the configuration page.	
Private key	OPC UA private key, click on the uploaded certificate to load it into the configuration page.	
Allow anonymous	Whether to enable user name and password login	
Username	Fill in the username	
Password	Fill in password	
Data select	All data Select data point Information model	All data
Select data point	You can select the data points you want to read. "Data selection" option to select "select data point" to have this option	
Model file (.xml)	Upload the information model (.xml) file, select "Information Model" in the "Data Selection" item to have this option	
Dependent model files	Select the number of information models to reference, up to 5 can be selected.	
Dependent Models 1-5	Upload the information model (.xml) file to be referenced	

Note: For a customized information model, the data point description item must be in the format of REG + Modbus address during modeling. For example, DO1 point description item fills in REG1000, and other items are customized.

6 BL205 Communication Example

6.1 Communication Between UaExpert and BL205

The BL205 collects DI, DO, and AI modules, selects basic128rsa15 as a security policy, and selects a signature and encryption method. The data format is based on a custom information model. Take an information model as an example. The data can also be uploaded directly according to the format of our company. For the definition of each configuration, please refer to chapter 5.8.7 OPC UA.

6.1.1 OPC UA Web Page Configuration

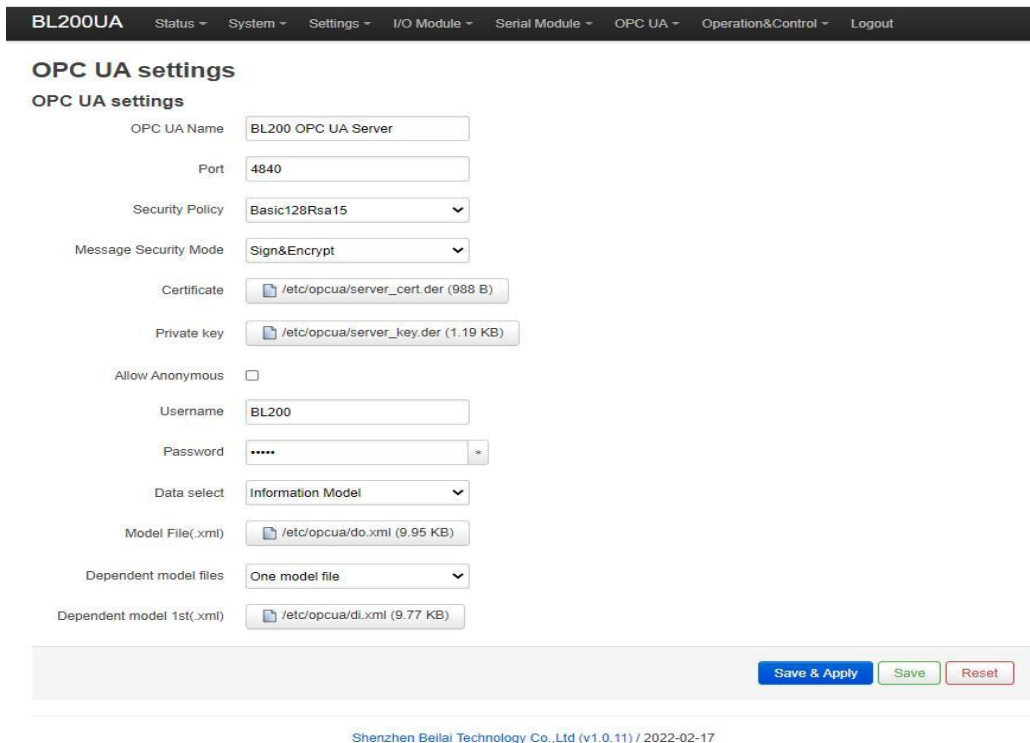

BL200UA Status - System - Settings - I/O Module - Serial Module - OPC UA - Operation&Control - Logout

OPC UA settings

OPC UA settings

OPC UA Name: BL200 OPC UA Server

Port: 4840

Security Policy: Basic128Rsa15

Message Security Mode: Sign&Encrypt

Certificate: /etc/opcua/server_cert.der (988 B)

Private key: /etc/opcua/server_key.der (1.19 KB)

Allow Anonymous:

Username: BL200

Password:

Data select: Information Model

Model File(.xml): /etc/opcua/do.xml (9.95 KB)

Dependent model files: One model file

Dependent model 1st(.xml): /etc/opcua/di.xml (9.77 KB)

Save & Apply Save Reset

Shenzhen Beilai Technology Co.,Ltd (v1.0.11) / 2022-02-17

Steps:

- (1) Fill in the OPC UA name, which can be customized to facilitate the OPC UA client to search and distinguish different OPC UA servers. For example: fill in "BL200 OPC UA Server".
- (2) The port number of the OPC UA server, default: 4840.
- (3) Security policy selection. For example, choose basic128rsa15.
- (4) Message security mode selection. For example, choose Signing and Encryption.

- (5) Upload the certificate and key, click "Select File" > click "Upload File" > select your certificate or key file, click Open > After it is displayed in the file name box, click Upload file > After uploading the file successfully The file you uploaded will be displayed in the box, click the certificate or key file you uploaded > then your certificate or key file will be displayed in the certificate or key item.
- (6) Whether to allow anonymity, because of the use of signature and encryption methods, allow anonymity is not checked.
- (7) Fill in the username and password. The client needs to fill in the username and password when connecting.
- (8) Select the data, because the user-defined information model is used, so choose the "information model".
- (9) Upload the information model file. The upload method is the same as uploading the certificate or key file. The uploaded file is an xml file.
- (10) Depends on the model file, whether there is a reference model, and how many references are there.
- (11) Dependent model: Upload the model you refer to. The upload method is the same as uploading the certificate or key file. The upload is an xml file.
- (12) Click "Save and Apply".

6.1.2 Send and Receive Data Using UaExpert Client

Open UaExpert (OPC UA client) and enter the OPC UA server IP and port.

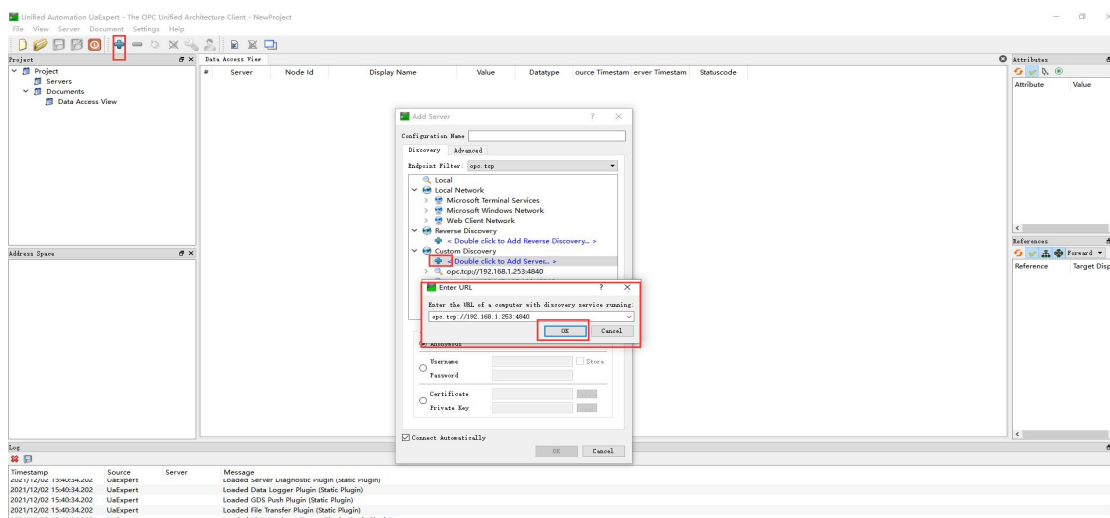

Click Search, click the searched OPC UA server, and click basic128rsa15 for Signature and Encryption.

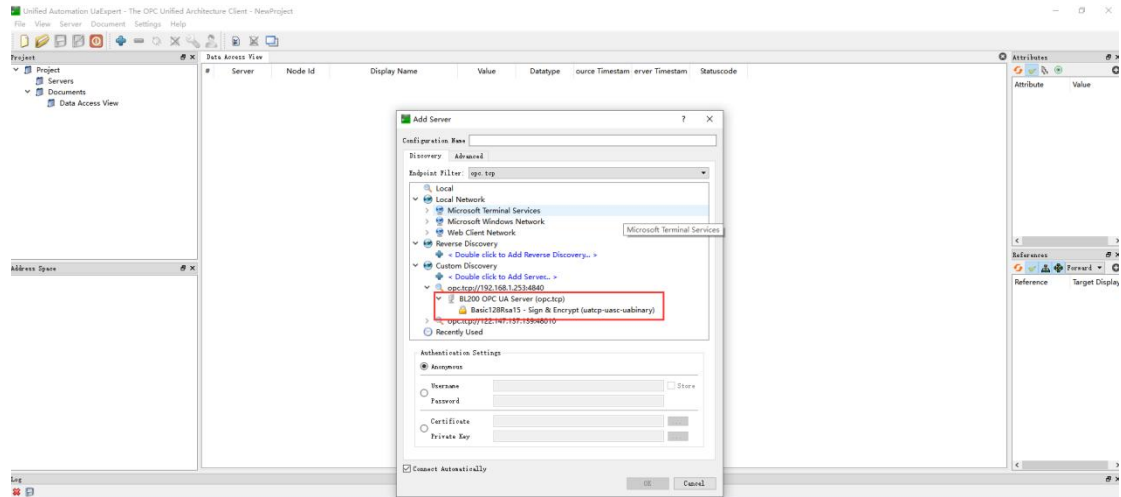

Enter the set username and password

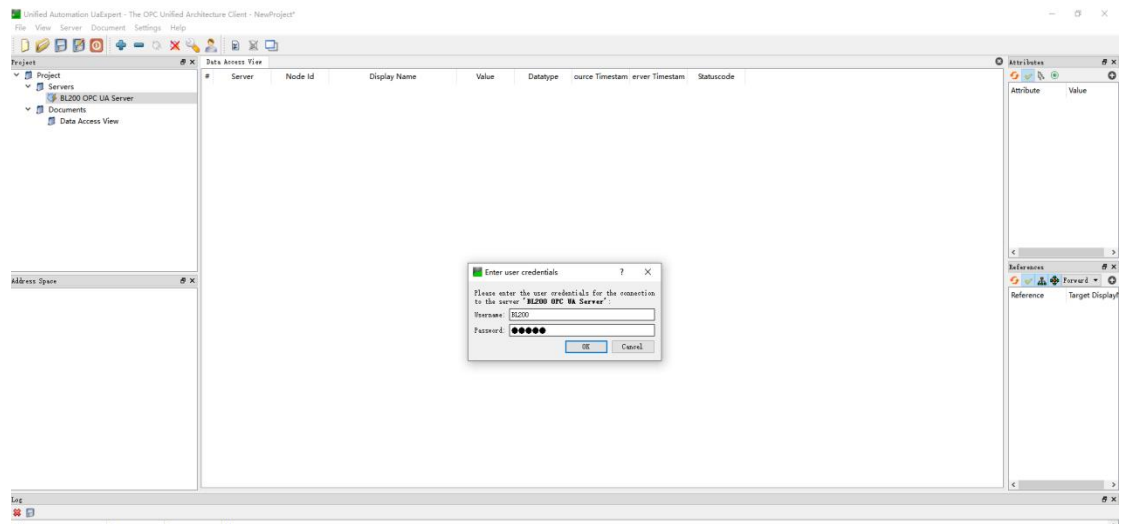

The collected data is as follows:

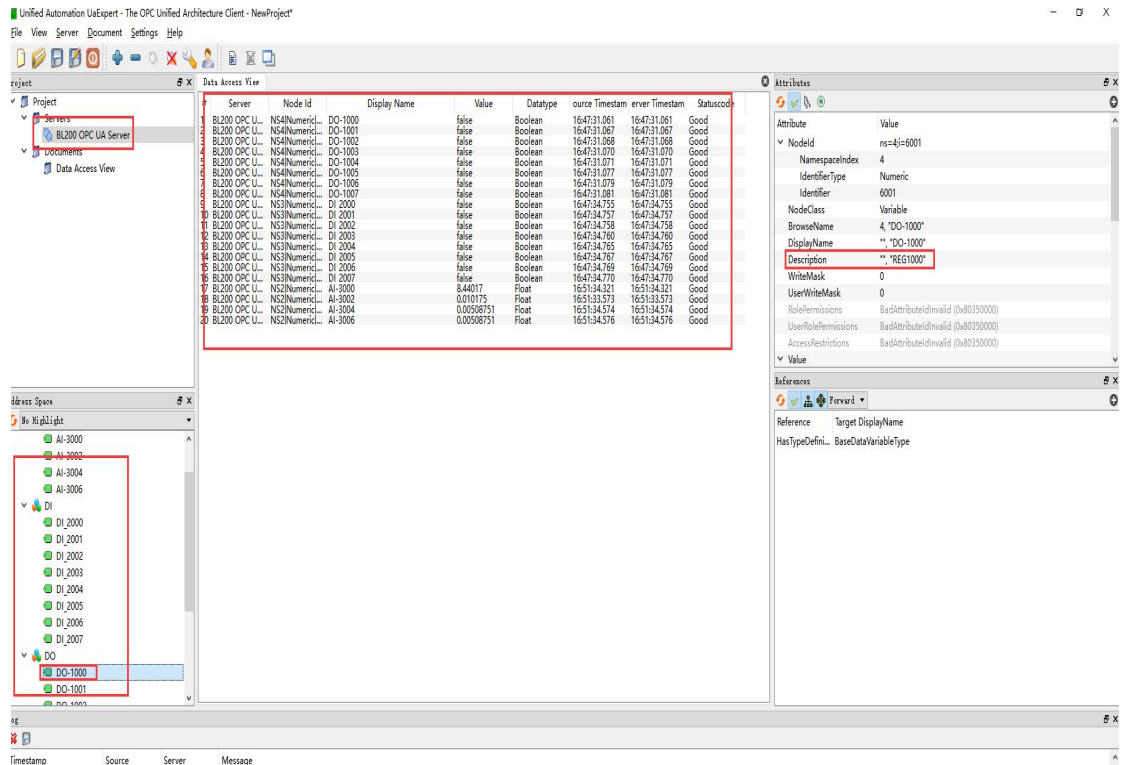

The description item of the custom information model data point must be REG+Modbus address, as shown in the description of the DO-1000 point in the figure above.

OPC UA client data delivery

Take the following data point DO-1000 as an example

IO status

IO Slot:2,Module Type:DO,Module Name:M2082

Channels	Modbus Address	Value	PowerOn Status	Open/Close
1	1000	Open	Open ▾	Open/Close
2	1001	Open	Open ▾	Open/Close
3	1002	Open	Open ▾	Open/Close
4	1003	Open	Open ▾	Open/Close
5	1004	Open	Open ▾	Open/Close
6	1005	Open	Open ▾	Open/Close
7	1006	Open	Open ▾	Open/Close
8	1007	Open	Open ▾	Open/Close

Back to Overview Save & Apply ▾ Save Reset

Shenzhen Beilai Technology Co.,Ltd (v1.0.11) / 2022-02-17

Click the value of the DO-1000 data point, it turned out to be false, there is no √ in the square, click once to put √, click the left mouse button in the blank space or press the [Enter] key on the keyboard.

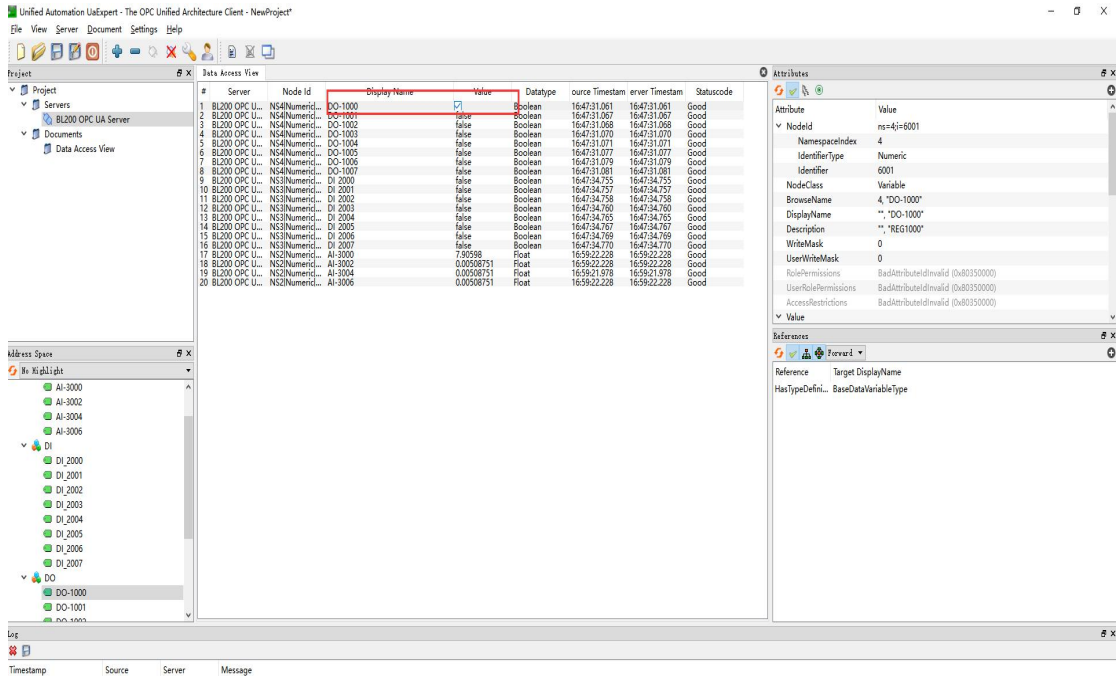

The OPC UA client will send a message successfully. Because the server responds quickly, you can see that the value has changed to "true".

The screenshot shows the UaExpert interface with a 'Data Access View' table and a 'Log' window. The table lists various nodes and their values, with DO-1000 highlighted in red. The log window shows a successful write operation to node NS4(Numeric)6001.

#	Server	Node Id	Display Name	Value	Datatype	Source Timestamp	Server Timestamp	Statuscode
1	BL200 OPC U.L.	NS4(Numeric)DO-1000	DO-1000	true	Boolean	165922729	165922729	Good
2	BL200 OPC U.L.	NS4(Numeric)DO-1001	DO-1001	false	Boolean	164731067	164731067	Good
3	BL200 OPC U.L.	NS4(Numeric)DO-1002	DO-1002	false	Boolean	164731068	164731068	Good
4	BL200 OPC U.L.	NS4(Numeric)DO-1003	DO-1003	false	Boolean	164731070	164731070	Good
5	BL200 OPC U.L.	NS4(Numeric)DO-1004	DO-1004	false	Boolean	164731071	164731071	Good
6	BL200 OPC U.L.	NS4(Numeric)DO-1005	DO-1005	false	Boolean	164731077	164731077	Good
7	BL200 OPC U.L.	NS4(Numeric)DO-1006	DO-1006	false	Boolean	164731079	164731079	Good
8	BL200 OPC U.L.	NS4(Numeric)DO-1007	DO-1007	false	Boolean	164731081	164731081	Good
9	BL200 OPC U.L.	NS3(Numeric)DI 2000	DI 2000	false	Boolean	164734753	164734753	Good
10	BL200 OPC U.L.	NS3(Numeric)DI 2001	DI 2001	false	Boolean	164734737	164734737	Good
11	BL200 OPC U.L.	NS3(Numeric)DI 2002	DI 2002	false	Boolean	164734758	164734758	Good
12	BL200 OPC U.L.	NS3(Numeric)DI 2003	DI 2003	false	Boolean	164734760	164734760	Good
13	BL200 OPC U.L.	NS3(Numeric)DI 2004	DI 2004	false	Boolean	164734755	164734755	Good
14	BL200 OPC U.L.	NS3(Numeric)DI 2005	DI 2005	false	Boolean	164734759	164734759	Good
15	BL200 OPC U.L.	NS3(Numeric)DI 2006	DI 2006	false	Boolean	164734767	164734767	Good
16	BL200 OPC U.L.	NS3(Numeric)DI 2007	DI 2007	false	Boolean	164734770	164734770	Good
17	BL200 OPC U.L.	NS2(Numeric)AI-3000	AI-3000	7.89072	Float	170005231	170005231	Good
18	BL200 OPC U.L.	NS2(Numeric)AI-3002	AI-3002	0.010175	Float	170004731	170004731	Good
19	BL200 OPC U.L.	NS2(Numeric)AI-3004	AI-3004	0.010175	Float	170004981	170004981	Good
20	BL200 OPC U.L.	NS2(Numeric)AI-3006	AI-3006	0.010175	Float	170005231	170005231	Good

Log Message: 2021/12/02 16:59:23.065 DA Plugin BL200 OPC U.L. Write to node NS4(Numeric)6001 succeeded [ret = Good (0x00000001)]

Check the DO status in the web configuration of BL205. DO1 is also changed from the original open to close.

The screenshot shows the web configuration interface for BL200UA. The 'IO status' table is displayed, showing the status of various IO modules. The DO module (M2082) is highlighted with a red box, indicating its status has changed from 'Open' to 'Close'.

IO Slot	Module Name	Module Type	Channel Number	Modbus Address	24V Address-State	Soft Version	IO Status	Channel Status
1	M1081	DI	8	2000-2007	9001-Power Off	5	Normal	Channel Status
2	M2082	DO	8	1000-1007	9002-Power Off	5	Normal	Channel Status
3	M3041	AI	4	3000-3006	9003-Power Off	5	Normal	Channel Status
4	M4044	AO	4	4000-4006	9004-Power Off	5	Normal	Channel Status
5	M6021	COM	2	0-0	9005-Power Off	5	Normal	Channel Status

IO status

IO Slot:2,Module Type:DO,Module Name:M2082

Channels	Modbus Address	Value	PowerOn Status	Open/Close
1	1000	Close	Open	Open/Close
2	1001	Open	Open	Open/Close
3	1002	Open	Open	Open/Close
4	1003	Open	Open	Open/Close
5	1004	Open	Open	Open/Close
6	1005	Open	Open	Open/Close
7	1006	Open	Open	Open/Close
8	1007	Open	Open	Open/Close

[Back to Overview](#)

[Save & Apply](#)

[Save](#)

[Reset](#)

Shenzhen Beilai Technology Co.,Ltd (v1.0.11) / 2022-02-17

7 Warranty

- 1) This equipment will be repaired free of charge for any material or quality problems within one year from the date of purchase.
- 2) This one-year warranty does not cover any product failure caused by man-made damage, improper operation, etc.

8 Technical Support

Shenzhen Beilai Technology Co., Ltd

Website: <https://www.bliiot.com>